



LONDON BUS SERVICES LIMITED

Specification for New Buses: Attachments

Version 2.5

Issued April 2024

Effective from Tranche 913



1 Preface

This protocol covers the assessments to be carried out for safety features fitted to Transport for London (TfL) buses.

Where an Original Equipment Manufacturer (OEM) perceives that a particular feature should be changed, this should be raised by the OEM with the competent authority (TfL) assessor present at the assessment, or in writing to the competent authority (TfL) Nominated Officer in the absence of an assessor. The competent authority (TfL) will assess the problem based on their judgment and provide instruction to the relevant Test Service/s.

OEMs are barred from directly or indirectly interfering with the assessment and prohibited from altering any characteristics that may impact the assessment, including but not restricted to vehicle setting, laboratory environment, etc.

2 Disclaimer & Copyright

TfL has taken all appropriate caution to guarantee that the information contained in this protocol is correct and demonstrates the prevailing technical decisions taken by the organisation. In the occasion that a mistake or inaccuracy is identified, TfL retains the right to make amendments and decide on the assessment and future outcome of the affected requirement(s).

© Copyright TfL 2024: This work is the intellectual property of TfL. A licence is permitted for this material to be distributed for non-commercial and educational use on condition that this copyright statement shows on the replicated materials and information is provided that the copying is by permission of TfL. To circulate otherwise or to republish will be deemed a breach of intellectual property rights.

Some sections of text in the attachments are reproduced with permission from Euro NCAP.



Table of Contents

Attachment 1: London Bus Cycle	5
Attachment 2: Noise Test Procedure and Limit Values	12
Attachment 3: Fleet Management Systems (FMS).....	19
Attachment 4: Installation Specification for Fleet Management Systems (FMS)	25
Attachment 5: Driver-Passenger Two-Way Communication Protocol	28
Attachment 6: Standard for the Fire Retardant Properties of Materials	33
Attachment 7: Wheelchair Floor Logo	36
Attachment 8: Staircase Handrail Layout	39
Attachment 9: Heating Ventilation and Air Conditioning (HVAC).....	41
Attachment 10: Destination Display Output.....	52
Attachment 11: CCTV	53
Attachment 12: Exterior and Interior Notices.....	62
Attachment 13: Operator Codes and Fleet Number Identification	63
Attachment 14: Free Issued Equipment	64
Attachment 15: Advanced Emergency Braking (AEB) Assessment Protocol.....	72
Attachment 16: Advanced Emergency Braking (AEB) Guidance Notes	107
Attachment 17: Intelligent Speed Assistance (ISA) Assessment Protocol.....	112
Attachment 18: Intelligent Speed Assistance (ISA) Guidance Notes	131
Attachment 19: Bus Vision Standard Assessment Protocol	134
Attachment 20: Bus Vision Standard Guidance Notes	161
Attachment 21: Blind Spot Mirrors Guidance Notes	166
Attachment 22: Camera Monitor Systems (CMS) Guidance Notes.....	168
Attachment 23: Rear view Camera Monitor Systems (CMS) Guidance Notes.....	171
Attachment 24: Blind Spot Warning (BSW) Assessment Protocol	174
Attachment 25: Blind Spot Warning Guidance Notes	187
Attachment 26: Pedal Application Error Assessment Protocol	193
Attachment 27: Pedal Application Error Guidance Notes.....	204
Attachment 28: Runaway Bus Prevention Assessment Protocol	211
Attachment 29: Runaway Bus Prevention Guidance Notes	221
Attachment 30: Acoustic Conspicuity Assessment Protocol.....	224
Attachment 31: Acoustic Conspicuity Guidance Notes.....	235
Attachment 32: Slip Prevention Assessment Protocol.....	238
Attachment 33: Slip Prevention Guidance Notes	243
Attachment 34: Occupant Friendly Interiors Assessment Protocol.....	248



Attachment 35: Occupant Friendly Interiors Guidance Notes.....	288
Attachment 36: VRU Frontal Crashworthiness Energy Absorption Assessment Protocol.....	293
Attachment 37: Bus VRU Frontal Crashworthiness Energy Absorption Assessment Protocol Guidance Notes	313
Attachment 38: Bus Front End Design – Minimum Geometric Requirements Guidance Notes	321
Attachment 39: Bus Front End Geometry Test and Assessment Protocol	325
Attachment 40: Bus Front End Design – Enhanced Geometric Requirements Guidance Notes	342
Attachment 41: Bus Front End Design – Wiper Protection Guidance Notes	346
Attachment 42: Complex Electronic Control Systems	348
Attachment 43 - Bus Acceleration Performance Assessment Protocol	354



Attachment 1: London Bus Cycle

1 Introduction

The LBC supersedes the former Transport for London MLTB procedure and encompasses a number of additions to more accurately reflect real-world driving conditions. TfL in conjunction with the LowCVP have harmonised both the former MLTB and LUB cycles, enhanced test procedures & setup conditions so that the real-world operating conditions are better reflected during the test process. This has enabled LowCVP and TfL to combine both test cycles into one bus test cycle called the “UK Bus Cycle” or UKBC.

The following preconditions, vehicle setup, in-test procedures and emission standards must be met in order for a TfL designated testing service to issue LBC certification.

2 Normative References

The following normative documents, in whole or in part, are referenced in this document and are indispensable for the correct application of this test and assessment protocol. For dated references, only the edition cited applies. For undated references, the latest edition of the referenced document (including any amendments) applies.

- United Nations Economic Commission for Europe (UNECE) Regulation 101: Uniform provisions concerning the approval of passenger cars powered by an internal combustion engine only, or powered by a hybrid electric power train with regard to the measurement of the emission of carbon dioxide and fuel consumption and/or the measurement of electric energy consumption and electric range, and of categories M1 and N1 vehicles powered by an electric power train only with regard to the measurement of electric energy consumption and electric range.

3 Definitions

For the purpose of this Protocol:

Kerb Weight:

- **ECU:** Electronic Control Unit
- **GVW:** Gross Vehicle Weight is the maximum weight of the vehicle permitted by law or defined by the vehicle OEM, whichever is the lower.
- **OEM: Original Equipment Manufacturer** – The company responsible for the manufacture of a completed bus, delivered to a bus operator
- **Passenger load:** The passenger load is a mass equal to the number of passengers multiplied by 68 kg plus 75kg to represent the driver.
- **Payload capacity:** is the GVW minus the ULW.



- **Test Bus:** is the vehicle being assessed for its emissions performance
- **Test Service:** The test service is an organisation designated by TfL to ensure comparative standards and quality of testing is achieved. Only an accredited testing authority service can be used, a list of approved authorities is available on request to TfL
- **Test weight:** Is the total mass of the vehicle at which testing shall be undertaken and is equal to the ULW plus the passenger load
- **ULW:** Unladen weight of the bus when all fluid levels are filled to recommended levels but no driver, passengers or luggage are on board.

4 Vehicle Preparation

The Test Bus shall be provided either by the OEM or by TfL. It shall be specified in accordance with the full applicable requirements of the London bus specification with respect to features required as part of this test.

The test service should request a vehicle specification sheet detailing the bus model, registration plate, ULW, GVW, passenger capacity: both seated and standing, engine start process).

OEMs and / or bus operators are permitted to be present during preparation and testing but are not permitted to interfere with or adjust the bus engine calibration/ after treatment/ propulsion / energy recovery system without full agreement of the testing service and TfL. A software ID and serial number will be noted by the test service and recorded on the test certificate issued. Any adjustments will be noted by the testing service. Laptops must not be connected during certification runs. ECU flash file must be as used in London operation. Certification runs must be in the same condition and consecutive.

The test bus shall be weighed by the testing service to obtain the ULW and compared to the ULW as certified on the side of the bus. The ULW as measured by the testing service shall be used for the purposes of the test.

The test Vehicle shall be loaded with a ballast mass equivalent to the passenger load, which shall be calculated as follows:

- a) If the seated passenger capacity multiplied by 68 kg per passenger is a mass of half of the payload capacity or more, then the passenger load shall be defined based a passenger number equal to half of the seated capacity.
- b) If the seated passenger capacity multiplied by 68 kg per passenger is a mass of less than half of the payload capacity, then the passenger load shall be defined based a passenger number equal to a quarter of the total passenger capacity (seated + standing).

Wheels and tyres shall meet the OEMs specifications. Tyre pressures shall be set to the OEM's recommendation and shall be the same for both track coastdown and dyno tests.

The exhaust system shall be checked to ensure it is free from significant leaks. The wheels and tyres used for track coastdown must be to OEM specification. Track coastdown and dyno tyre pressure must be the same.



If a coastdown is required, the test bus must be delivered to the Test service ahead of the scheduled test date.

The Test Bus must be in a safe on-road condition for testing. No warning lights shall be present on instrument panel (except if present due to a modification to allow vehicle to drive on a chassis dynamometer) and power steering **MUST** be active.

5 Test Procedure & Limit Values

5.1 All Buses

Testing shall in principle follow UNECE Regulation 101, whole vehicle testing procedure for passenger cars, with regards to the capabilities of the test facility. The bus is linked to a chassis dynamometer in a test chamber for emissions testing. The test chamber is held at a temperature of 10°C +/-2°C and vehicle tracking fans are positioned to simulate actual road speed in the test chamber.

All power operated passenger doors shall be opened and closed on every designated bus stop, except during a warmup phase. Doors shall not be opened at any other time during the test.

All bus ancillaries must be turned on including; all interior lighting, exterior sidelights and dipped beam headlamps.

Drivers cab demisters shall be turned on to full.

50% of available opening saloon windows shall be open on upper & lower saloon, evenly distributed and every other window each side.

Interior heating shall be set at 17°C ± 2°C (if not automatically controlled) for diesel & diesel-electric hybrid vehicles, 15°C for battery & fuel cell electric vehicles with a ±1°C variation during test permitted. Heating shall be switched on at the start of the warmup phase of the test procedure. Doors shall remain closed throughout the warmup phase.

The Test service shall monitor the temperature in the centre aisle. The combined average saloon temperature per test run shall be recorded on the test certificate. The positions at which temperatures shall be monitored are defined as:

- a) Lower Saloon, 1m above the saloon floor
- b) Centre front of bus (0.5m from windscreen)
- c) Centre of middle aisle
- d) Centre rear (0.5m from back of bus)
- e) Next to front windscreen demister vent

Upper Saloon, 1m above saloon floor:

- a) Centre front of bus (0.5m from windscreen)
- b) Centre of middle aisle
- c) Centre rear (0.5m from back of bus)

None of the above temperature readings should fall outside of the permitted range at any time. Temperature variation outside of permitted limits may result in a failed test, subject to review by TfL.



5.2 Conventional Diesel and Diesel Electric Hybrid Buses

The UKBC is made up of the following phases based on the original LUB and MLTB cycles but in a revised order.

- a) Outer Urban Phase
- b) Inner Urban Phase
- c) Rural Phase

The Precertification warm up run shall use only the Outer Urban Phase.

Note: In the previous LBSL emission procedure, warm-ups used the full MLTB cycle.

The data from all three phases from the new UKBC is combined to give an average emission performance and is used for certification by LowCVP.

Data from the LBC, i.e. the Outer Urban and Inner Urban phases, is combined to give an average emission performance and is used for certification by TfL. This must be extracted from a full UKBC run. To reflect the changes in procedure and harmonisation with LowCVP into a single UK bus test the Outer and Inner Urban phases extract from UKBC will called London Bus Cycle, LBC.

To clarify:

- a) UKBC = Outer + Inner + rural phases
- b) LBC = Outer and Inner phases (Previously MLTB)
- c) The LBC shall not be tested in isolation. It must be extracted from a full UKBC test. The rural phase of tests must be carried out on every vehicle
- d) Pre-test cycle warmup shall be an Outer Urban Phase, and shall be performed prior to each test run

The buses must arrive at the test site with a full tank of fuel, including Ad-Blue. A one litre fuel sample shall be taken and retained for analysis if required.

Well-to-wheel emissions factors will be taken from the most recently published UK Government's (currently DBEIS) annual average carbon conversion factors for UK fuels e.g. Pump diesel inclusive of biofuel content.

The bus will be run over three validated UKBC cycles of the above test to produce an average result in the report from the extracted Outer and Inner Urban phases (LBC). Cycles must be consecutive unless net energy change (NEC) exceeds +/- 5% in which case another test shall be required.

NEC shall be calculated as per the revised LBC procedure, document available on request to TfL.

Bag analysis of the following emissions is reported for each test. Emissions are reported on each of the three phases (outer, inner, rural) and a combined overall test average, in grammes per kilometre for each pollutant.

- a) Engine NO_x, NO, NO₂, HC, CO, CO₂ at 1 Hz
- b) Tailpipe NO_x, NO, NO₂, HC, CO, CO₂ at 1 Hz
- c) FTIR at tailpipe (NO, NO₂, N₂O, methane (CH₄), NH₃)
- d) Particle number to PMP method



- e) Three dilute ‘bags’ collected and analysed for NO_x, CO, HC & CO₂
- f) PM is measured over the combined Outer and Inner urban phases on one filter, per test cycle. The Rural phase shall be collected on a single filter, per test cycle. The weighted average mass of the Outer/Inner and the Rural phase shall be calculated for the UKBC
- g) Fuel Consumption is calculated using Carbon Balance Method, reported in Litres / 100km

An emission test summary sheet showing all ‘bag’ data shall be provided to TfL showing all ‘legislated’ pollutants along with a TfL emissions summary certificate indicating CO_{2-e}.

A “hybrid” bus is defined as a bus that has on board energy storage which is then used to provide vehicle traction.

For hybrid buses that have the ability to operate in electric mode for more than 1km, the effect of the transition from electric to diesel on SCR efficiency will need to be demonstrated. For these vehicles, the test procedure must be agreed with TfL in advance of testing being conducted.

The emissions measured on average over the extracted LBC, shall not exceed the limit values defined below:

Emission	Double Deck		Single Deck	
	Standard Diesel	Hybrid Diesel-Electric	Standard Diesel	Hybrid Diesel-Electric
CO ₂ g/Km	1250	980	900	750
NO _x g/Km	0.5			
PM g/Km	0.01			
PN/Km	6E+11			
CO _{2-e} g/Km	<5% CO _{2-Tot}			
NH ₃	10ppm (average) 25 ppm (peak)			

Where:

- CO_{2-e} is equivalent CO₂ due to non-CO₂ Greenhouse Gases at tailpipe
- CO_{2-Tot} is Total CO₂, the combination of tailpipe CO₂ and CO_{2-e}

TfL reserves the right to review emissions test limits at any time, however limits are not subject to an annualised update on publication of DBEIS annual UK average carbon conversion factors.



5.3 Battery Electric Buses

Buses powered by battery electrical energy storage shall be tested over the complete UKBC procedure. It shall be assumed that they are charged using average UK grid-sourced electricity.

Energy consumption over the LBC will be extracted from the full UKBC via the use of current clamps connected to the high voltage (HV) battery.

The vehicle shall be driven over a minimum of 4 consecutive repeats of the UKBC with minimal breaks between the cycles. No prior warm up cycle before test run is required (A short warm up may be performed by the test house, at their discretion).

As no warm-up run is required, the saloon temperature limit of $15 \pm 1^{\circ}\text{C}$ will not apply to the first test of the four consecutive test runs of a battery EV. The correct saloon temperature shall be achieved on all other subsequent runs.

The vehicle shall be fully charged in a set location, less than 500m from the chassis dynamometer. The vehicle should be electrically fully charged using the OEMs recommended equipment and process. OEMs must liaise with the test house to ensure the correct charging equipment is provided for vehicle charging.

If necessary the vehicle shall be moved to the test cell by driving or otherwise, but aiming to use as little energy as possible. This is to save potential costs for facility utilisation whilst charging.

The testing shall commence as soon as possible after the vehicle is removed from charge and within 6 hours as a maximum.

For the purpose of creating a dynamometer set of coefficients, the test house is allowed to use the dynamometer to motor the driven axle up and then allow it to coastdown as controlled by the dynamometer. Otherwise rotation of the wheels should be kept to a minimum.

The distance travelled shall be recorded by the dynamometer. If the vehicle warns the driver to stop and recharge or cannot achieve 20km/h then the test shall be aborted.

The OEM will provide the ability for the test house to read the traction battery State Of Charge (SOC). This will be recorded by the test house at the start and end of each phase of the LBC.

The OEM shall declare the minimum SOC that the vehicle will operate normally at, as well as the maximum available on-board energy that can be used for vehicle operation in kWh.

The vehicle shall be moved, if required, using minimal energy, to be recharged using the same equipment prior to testing not more than 1 hour after the completion of the 4th cycle.

The vehicle shall be fully recharged during which the energy drawn from the mains by the charger shall be measured on a continuous basis as required in Regulation 101, and recorded.

The energy consumption shall be calculated as the total energy consumed by the mains charger (including energy lost during charge process) divided by the recorded distance travelled over the 4 UKBC tests. This shall be expressed as kWh/km.



The overall vehicle emissions factors in g/km will be derived using the consumption calculated in item 37 above in kWh/km and the national grid average emissions as stated by the latest UK Government National averages for UK Grid electricity, as stated in point 21.

From the SOC and distance travelled data this shall be linearly extrapolated to equate to an estimated range distance based on the declared minimum SOC recommended in service to maintain battery warranty.

5.4 Plug-in & Opportunity Charging Hybrid Buses

OEMs should discuss the operating characteristic for their plug-in vehicles with TfL and the test house to ensure the optimum test process is adopted.

Please contact TfL directly if you have a technology not considered here or wish to gain further clarity on the test process detail.

5.5 Fuel Cell Buses

The evaluation process is currently under development.



Attachment 2: Noise Test Procedure and Limit Values

1 Introduction

This procedure is intended to provide objective measurement of both exterior and interior noise associated with the bus

2 Normative References

The following normative documents, in whole or in part, are referenced in this document and are indispensable for the correct application of this test and assessment protocol. For dated references, only the edition cited applies. For undated references, the latest edition of the referenced document (including any amendments) applies.

- London Bus Services Limited New Bus Specification: Section 5.4
- ISO 10844:2014 – Acoustics: Specification of test tracks for measuring noise emitted by road vehicles and their tyres.
- IEC 61672-1:2013 – Electroacoustics – Sound level meters – Part 1: Specifications
- IEC 60942:2017 – Electroacoustics - Sound Calibrators
- ISO 362:2007 – measurement of noise emitted by accelerating road vehicles – engineering method – part 1: M and N categories
- United Nations Economic Commission for Europe (UNECE) Regulation 51: Uniform Provisions Concerning the Approval of Motor vehicles having at least 4 wheels with regard to their sound emissions - 03 Series of amendments.
- ANSI S3.5-1969, “Methods for Calculation of the Speech Intelligibility Index”

3 Definitions

- **Articulation Index (AI)** - A quantitative measure of the intelligibility of speech; the percentage of speech items correctly perceived and recorded. An articulation index of 100% means that all speech can be understood, 0% means that no speech can be understood.
- **A-weighting** - Sound intensity is spread out across a wide range of frequencies. However, the human ear is not as good at hearing very high or very low frequencies as it is those in the mid range. The standard decibel scale treats all frequencies equally and is referred to variously as flat, linear or Z weighted. An A-weighted decibel scale dB(A) has been developed that weights sound intensities at lower and higher frequencies differently so it more closely represents a human response to sound at relatively low levels.
- **Decibels (dB)** - A logarithmic ratio of sound intensity relative to a threshold level of 0 dB. Zero dB is the quietest sound audible to a healthy human ear.



From there, every increase of 3dB represents a doubling of the sound intensity.

- **L_{EQ}** - Equivalent Sound Level and is defined as the constant sound level that would produce the same cumulative sound intensity as a sound whose level varies over a defined recording period
- **Maximum SPL** - The peak value of SPL recorded during any given measurement period.
- **OEM: Original Equipment Manufacturer** – The company responsible for the manufacture of a completed bus, delivered to a bus operator
- **Sound Intensity** - The power carried by sound waves per unit area in a direction perpendicular to that area. Its standard unit is the watt per square metre. Clearly this is a complex measurement involving multiple units and the range of sound intensity can be very large. Thus, sound intensity is usually measured in Decibels (dB).
- **Sound pressure level (SPL)** - Related to sound intensity and is the difference between ambient air pressure and the peak pressure caused by the sound wave and is measured in units of Pascal. However, sound pressure levels are also often expressed in Decibels. Hearing is directly sensitive to sound pressure.

4 Test Site

The surface of the test track and the dimensions of the test site shall be in accordance with ISO 10844:2014.

The site should allow for free-field propagation of sound, therefore there shall be no obstacles (inclusive of any observers) which could affect the sound field within the vicinity of the microphone.

5 Environmental Conditions

Ambient air temperature must be within a temperature range of 5°C to 40°C.

Wind speed, including gusts, must not exceed 5 ms⁻¹.

6 Instrumentation

Class 1 sound level meters, in accordance with IEC 61672, must be used for exterior and interior measurements.

Calibration of the sound level meters must be done at the start of every measurement session, using a precision sound calibrator (Class 1 or better, in accordance with IEC 60942).



7 Test Vehicle

The test vehicle shall be representative of an in-service vehicle, fitted with all London specific devices, and complete with regards to base vehicle build.

The tyre tread depths shall be a minimum of 1.6 mm and tyre pressures are to be declared by the OEM.

All auxiliary systems must be fully functioning. It is required of the OEM to provide a mechanism to enable the cooling fans to operate at maximum speed.

Any non-conformance must be declared prior to testing, and testing can be continued following the discretion of TfL. It is the OEM's responsibility to ensure that in the event of missing devices, base vehicle components, etc. appropriate ballast is declared.

The peak power engine speed must be declared prior to test.

8 Dynamic tests

8.1 General

Measurement locations shall be as specified in accordance with ISO 362:2007 (as per ECE R51-03).

If a measurement is not able to be completed, then explanation is required.

All sound measurements shall be A-weighted, fast response.

Maximum or LEQ sound pressure levels (SPL) values to be recorded, dependent on test.

A minimum of 4 results to be recorded (within 2 dB).

8.2 Exterior

8.2.1 Vehicles with Internal Combustion Engines

Tests shall be undertaken as defined in UNECE R51-03

When the reference point passes line BB, the test vehicle speed must be 35 ± 5 kmh⁻¹ and with an engine speed between 85 and 89% of the peak power engine speed.

If the test vehicle speed or engine speed is not met from the above point, then consult ECE R51-3 Annex 3 Para. 3.1.2.2.1.2., and conduct further tests as declared.

Between lines AA and BB, stable acceleration shall be ensured.

The tests shall be completed with cooling fans disabled.

The maximum sound pressure level, or arithmetic average as per ECE R51-3 Annex 3 Para. 3.1.3.2. (if further test speeds were required), shall be declared



8.2.2 Vehicles with Hybrid (Parallel and Series) Powertrains

Tests shall be undertaken as defined in section 8.2.1, but separate tests shall be undertaken with internal combustion engines operational and non-operational.

It is expected that the OEM will provide suitable advice or mechanisms to enable full control over the internal combustion engine, else low speed mileage accumulation will be completed to decrease the state of charge of the high-voltage batteries to force the internal combustion engine to operate.

8.2.3 Stationary Vehicle Sound Emissions and Compressed Air Noise

Tests shall be undertaken in accordance with UNECE R51-03 Annex 3 Para. 3.2. and Annex 5.

8.2.4 ECE R51-03 Improved

The tests described in section 8.2 shall be repeated but with cooling fans at maximum operational speed.

8.3 Interior

All interior sound measurements shall be completed at the following microphone positions. The microphone shall be positioned 1.0 m vertically above the seat squab in all cases:

- a) Driver, right-hand ear position.
- b) Forward most seated position, closest to centreline of test vehicle.
- c) Directly above rear axle, closest to centreline of test vehicle.
- d) Rear 5-way, centre seat.

If upper saloon (i.e. double deck bus), then additional measurements at:

- a) Forward-most, closest to centreline of test vehicle.
- b) Rear 5-way, centre seat.

Test conditions and measurements shall be:

- a) Constant speed, 16 kmh-1, HVAC system off: LEQ SPL, 5 second measurements.
- b) Constant speed, 40 kmh-1, HVAC system off: LEQ SPL, 5 second measurements.
- c) Acceleration speed, 16 - 40 kmh-1, HVAC system off: Maximum SPL.



9 Static tests

9.1 General

If a measurement is not able to be completed, then explanation shall be required.

All measurements shall be A-weighted, fast response.

Maximum or LEQ sound pressure levels (SPL) values shall be recorded, dependent on test.

A minimum of 4 results shall be recorded (within 2 dB(A)).

Arithmetic average to be declared.

9.2 Exterior

9.2.1 Door Warning Device(s)

Microphone position shall be 1 m from outermost face of door aperture (away from centreline of test vehicle), bisection across door width, and 1.2 m high.

Maximum SPL shall be declared.

Requirements are applicable to each door.

9.2.2 Ramp Warning Device(s)

Microphone position shall be 1 m from outermost edge of ramp (away from centreline of test vehicle), bisection across ramp width, and 1.2 m high.

Maximum SPL shall be declared.

Applicable to each ramp fitted.

9.3 Interior

Interior measurements for 9.3.3 and 9.3.4 to be completed at the following microphone positions, all are 1.0 m high from seat squab:

- a) Driver, right-hand ear position.
- b) Forward most seated position, closest to centreline of test vehicle.
- c) Directly above rear axle, closest to centreline of test vehicle.
- d) Rear 5-way, centre seat.

If upper saloon (i.e. double deck bus), then additional measurements at:

- a) Forward-most, closest to centreline of test vehicle.
- b) Rear 5-way, centre seat.



9.3.1 Door Warning Device(s)

Microphone position to be 0.5 m from innermost face of door aperture (towards centreline of test vehicle), bisection across door width, and 1.2 m high.

Maximum SPL shall be declared

Requirements are applicable to each door.

9.3.2 Ramp Warning Device(s)

Microphone position to be 0.5 m from outermost edge of ramp (towards centreline of test vehicle), bisection across door width, and 1.2 m high.

Maximum SPL shall be declared.

Applicable to each ramp fitted.

9.3.3 Engine Idle, HVAC system off

The sound pressure level (LEQ) measured over 5 seconds shall be declared

9.3.4 Engine Idle, HVAC system on

Tests shall be undertaken at maximum fan speed.

The sound pressure level (LEQ) measured over 5 seconds shall be declared

10 Articulation Index (AI)

Further analysis shall be done on measured data using ANSI S3.5-1969, "Methods for Calculation of the Speech Intelligibility Index".

Individual AI values to be declared for each measurement location and discrete test.

Average of AI values to be declared.



11 Sound Pressure Level Limits

Table 2_1. Noise Limits for all powertrain types

Single/ Double	Test Element	Limit, dB(A)	AI, %
Both	8.2.2 ECE R51-03 "Motion", Exterior	76/78/80 ¹	N/A
Both	8.2.2 ECE R51-03 "Static" , Exterior	N/A	N/A
Both	8.2.3 ECE R51-03 "Compressed Air" , Exterior	72	N/A
Both	8.2.4 ECE R51-03 Improved, Exterior	75/77/79 ²	N/A
Single	8.3 Constant Speed, 16 kmh ⁻¹ , HVAC off, Interior	59	
Single	8.3 Constant Speed, 40 kmh ⁻¹ , HVAC off, Interior	66	
Single	8.3. Acceleration, 16 - 40 kmh ⁻¹ , HVAC off, Interior	67	
Double	8.3. Constant Speed, 16 kmh ⁻¹ , HVAC off, Interior	62/65 ³ 52/54 ⁴	
Double	8.3 Constant Speed, 40 kmh ⁻¹ , HVAC off, Interior	69/70 ⁵ 62/62 ⁶	
Double	8.3 Acceleration, 16 - 40 kmh ⁻¹ , HVAC off, Interior	70/72 ⁷ 60/61 ⁸	
Both	9.2.1 Door Warning Device, Exterior		N/A
Both	9.2.2 Ramp Warning Device, Exterior	75	N/A
Both	9.3.11 Door Warning Device, Interior	75	N/A
Both	9.3.22 Ramp Warning Device, Interior		N/A
Both	9.3.3 Powertrain Idle, HVAC off, Interior	50	
Both	9.3.4 Powertrain Idle, HVAC on, Interior	72	

¹ Dependent on engine power output (in kW).

² Dependent on engine power output (in kW), -1 dB(A) from ECE R51-03 Para. 6.2.2.

³ Lower deck Front/Rear positions.

⁴ Upper deck Front/Rear positions.

⁵ Lower deck Front/Rear positions.

⁶ Upper deck Front/Rear positions.

⁷ Lower deck Front/Rear positions.

⁸ Upper deck Front/Rear positions.



Attachment 3: Fleet Management Systems (FMS)

1 Introduction

This initial specification sets out as mandatory and desirable implementation of the Fleet Management System (FMS). At some point in the near future desirable requirements will be substantially enhanced and made mandatory. Bus-FMS CAN to IP Network Bridge will be provided by London Buses.

For full understanding of this Attachment it should be read in conjunction with London Bus Services Limited New Bus Specification: Attachment 4: Installation Specification for Fleet Management Systems (FMS) and London Bus Services Limited New Bus Specification: Section 6.4.2

2 Mandatory

2.1 FMS v3

All buses will be supplied with FMS version 3 implemented.

The data required from the interface is shown in Table 3_1 below.

Parameters for Bus-FMS Version 3	Data required
1.1.1 Fuel Consumption: LFC 7	Yes
1.1.2 Dash Display: DD 8	Yes
1.1.3 Electronic Engine Controller #1: EEC1 9	Yes
1.1.5 Vehicle Identification: VI 11	No
1.1.6 FMS-standard Interface Identity / Capabilities: FMS 12	Yes
1.1.7 High Resolution Vehicle Distance: VDHR 14	Yes
1.1.10 Ambient Conditions: AMB 18	Yes
1.1.12 Fuel Economy: LFE 20	Yes
1.1.15 After treatment 1 Diesel Exhaust Fluid Tank 1 Information: AT1T1I 23	Yes
1.3 Parameters for Bus FMS-Standard	
1.3.1 Cruise Control/Vehicle Speed: CCVS 36	Yes
1.3.2 Electronic Engine Controller #2 : EEC2 38	Yes
1.3.3 Door Control 1: DC1 39	Yes
1.3.4 Door Control 2: DC2 40	Yes

Table 1_1 Parameters for Bus-FMS version 3

In the event that the data items detailed in Table 3_1 are not available a formal request to LBSL shall be made for a concession.



LBSL has a specific requirement for the use of the following data items listed in Table 3_2 below.

1.1.10 Ambient Conditions: AMB 18	This will be the temperature of the upper deck measured at an agreed location.
1.1.16 FMS Tell Tale Status: FMS1 24	No mandatory alarms are defined for buses. London buses will work with suppliers to agree the mandatory set.
1.3.3 Door Control 1: DC1 39	Monitor open/closed the status of the door. Monitoring the deployment of the wheelchair ramp.
1.3.4 Door Control 2: DC2 40	Status of each of the doors, Door 1 = front door Door 2 = middle door Door 3 = rear door on New Route Master only. Locked refers to Conductor mode. Note – driver only/crew mode is a separate input from Door Control.
1.3.5 Time / Date : TD 41	GMT

Table 3_2 LBSL Specific use data requirements

Where the data item is a measured value LBSL requires the accuracy of the data items reported along with documentary evidence. Should LBSL consider the accuracy of the data provided not fit for purpose LBSL will work with the supplier to improve the accuracy such that it is fit for purpose.

2.2 Details of the location and physical interface.

Specification of the capability of the Bus-FMS CAN Interface. This should include, as a minimum, configuration management and support for remote Operational Management.



3 Desirable

3.1 Capability

The data items listed in Table 3_3 are desirable and thus if available with the current implementation should be made available. If not available a plan should be put in place and agreed with LBSL to provide the data.

1.1.4 Engine Hours, Revolutions: HOURS 10
1.1.8 Tachograph : TCO1 15
1.1.9 Engine Temperature 1: ET1 17
1.1.14 High Resolution Fuel Consumption (Liquid): HRLFC 22
1.1.16 FMS Tell Tale Status: FMS1 24

Table 3_3: LBSL desirable data requirements

The following data element in Table 3_4 is under consideration and should be discussed with London Buses.

1.3.8 Air Suspension Control 4 : ASC4 44
--

Table 3_4: LBSL data under consideration

3.2 Operability

London Buses need to ensure that the implementation of FMS across the entire fleet is supported by the capabilities to operate FMS with minimal day to day involvement. The specification below will be required and will be finalised through discussions with suppliers.

3.2.1 Configuration Management

It shall be possible for the user to configure the interface to enable the data elements required and set the repetition interval as defined by the FMS specification.

It shall be possible to configure the FMS gateway remotely via either

- Bus-FMS CAN to IP Network Bridge using a standard protocol – TBD
- OR
- A LAN port on the Bus-FMS CAN Interface using a standard protocol – TBD



3.2.2 Operational Management

The Bus-FMS CAN Interface will:-

- Initialise at ignition on.
- Maintain the configuration.
- Generate alarms when the device is faulty or the CAN input has failed.
- Provide monitoring & diagnostics capabilities to allow analysis of the data provided and interface.

3.3 FMS Energy Extensions

Following consultation LBSL require delivery of additional data from the CAN BUS which give a clear view on the energy consumption per bus for Hybrid, Electric and Fuel Cell buses. This data shall be provided through an FMS2IP bridge. This will require substantial development on behalf on the OEM's. This desirable requirement hereby gives notice that these developments should be initiated. The data required is in table 3_5 below.

Parameter	Unit	Sample time (s)	Resolution	Range	Bits	Bytes	Data Source	PGN	SPN
Brake pedal position	%	0.1	1%	0-100%	7	1	Brake pedal		521
Operational mode	unit	1	Off/EV/Hybrid/En-route charge/Overnight charge		3	1	Powertrain control system		
Power Pack charge/discharge (battery)	kW	1	0.5kW	-3000 to 3000	16	2	BMS		
Power Pack Voltage	V	1	0.1V	0 to 3000	16	2	BMS		
Power Pack Current	I	1	0.1A	-3000 to 3000	16	2	BMS		
Power Pack charge/discharge (supercap)	kW	0.1	0.5kW	-3000 to 3000	16	2	BMS		
Power Pack Voltage (supercap)	V	0.1	0.1V	0 to 3000	16	2	BMS		
Power Pack Current (Supercap)	I	0.1	0.1A	-3000 to 3000	16	2	BMS		
Power Pack SoC (Supercap)	%	0.1	1	100%	8	1	BMS		
Power Pack SoC (Battery)	%	1	0.5	100%	8	1	BMS		
Diesel heater fuel tank level	%	10	0.01	100%	7	1	Vehicle CAN		
Ancillary power	kW	1	0.1kW	0-50	9	2	Ancillary sub-system output (e.g. HVAC)		



Traction power	kW	1	0.1kW	-3000 to 3000	16	2	Motor Input		
Phase shift									
Traction Voltage	V	1	0.1V	0 to 3000	16	2	Motor Input		
Traction Current	I	1	0.1A	0 to 3000	16	2	Motor Input		
Generator output	kW	1	0.1kW	0 to 3000	16	2	Generator output		
Phase shift									
Generator Voltage	V	1	0.1V	0 to 3000	16	2	Generator output		
Generator Current	I	1	0.1A	0 to 3000	16	2	Generator output		
En-route charger Power	kW	1	0.1kW	0 to 3000	16	2	Rectifier output at the Vehicle side		
En-route charger Voltage	V	1	0.1V	0 to 3000	16	2	Rectifier output at the Vehicle side		
En-route charger Current	I	1	0.1A	0 to 3000	16	2	Rectifier output at the Vehicle side		
Phase shift									
Overnight charger power	kW	1	0.1kW	0 to 3000	16	2	Rectifier output at the Vehicle side		
Overnight charger voltage	V	1	0.1V	0 to 3000	16	2	Rectifier output at the Vehicle side		
Overnight charger Current	I	1	0.1A	0 to 3000	16	2	Rectifier output at the Vehicle side		
Phase shift									
Ignition	1/0	1	binary	1/0	1	1	Ignition key activation		
Mean Power Pack1 temp limits exceeded	On/off	1	Binary	1/0	1	1	BMS	Tell-tale	
Max cell temp in the Power Pack1 limits exceeded	On/off	1	Binary	1/0	1	1	BMS	Tell-tale	
Min cell temp in the Power Pack1 limits exceeded	On/off	1	Binary	1/0	1	1	BMS	Tell-tale	
Mean Power Pack2 temp limits exceeded	On/off	1	Binary	1/0	1	1	BMS	Tell-tale	
Max cell temp in the Power Pack2 limits exceeded	On/off	1	Binary	1/0	1	1	BMS	Tell-tale	
Min cell temp in the Power Pack2 limits exceeded	On/off	1	Binary	1/0	1	1	BMS	Tell-tale	
Mean Power Pack3 temp limits exceeded	On/off	1	Binary	1/0	1	1	BMS	Tell-tale	
Max cell temp in the Power Pack3 limits exceeded	On/off	1	Binary	1/0	1	1	BMS	Tell-tale	
Min cell temp in the Power Pack3 limits exceeded	On/off	1	Binary	1/0	1	1	BMS	Tell-tale	



Mean Power Pack4 temp limits exceeded	On/off	1	Binary	1/0	1	1	BMS	Tell-tale	
Max cell temp in the Power Pack4 limits exceeded	On/off	1	Binary	1/0	1	1	BMS	Tell-tale	
Min cell temp in the Power Pack4 limits exceeded	On/off	1	Binary	1/0	1	1	BMS	Tell-tale	
Mean Power Pack5 temp limits exceeded	On/off	1	Binary	1/0	1	1	BMS	Tell-tale	
Max cell temp in the Power Pack5 limits exceeded	On/off	1	Binary	1/0	1	1	BMS	Tell-tale	
Min cell temp in the Power Pack5 limits exceeded	On/off	1	Binary	1/0	1	1	BMS	Tell-tale	

Table 3_5: Vehicle CANBus data requirements and details



Attachment 4: Installation Specification for Fleet Management Systems (FMS)

1 Introduction

This attachment provides requirements relating to the installation of the fleet management systems.

For full understanding of this Attachment it should be read in conjunction with London Bus Services Limited New Bus Specification: Attachment 3: Fleet Management Systems (FMS) and London Bus Services Limited New Bus Specification: Section 6.4.2

2 Definitions

- **Cable** - A generic term used for a wire or loom and an Ethernet cable.
- **Channel** - A channel is an unrestricted free space through which a cable can be easily drawn. It can be specifically designed for the purpose or make use of the existing design.
- **Fixing** – A point to which a cable can be secured.
- **Roof space** - The entire void between the inner and outer roof and coving skins.
- **Void** - An enclosed space.

Note: The terms 'channel' and 'void' largely overlap. Channels will normally make use of voids, but the importance is that a channel will offer an unrestricted cable passage from end to end.

3 General Principles for Cabling Access

Designated cable channels should be provided within the voids between the vehicle body inner and outer skins such that cables can easily be drawn between all equipment compartments and any other part of the vehicle in which equipment may need to be installed.

In particular, there shall be easy cable routes between equipment compartments and the following areas:

- a) Cab dashboard, header panel, offside console and coving, rear bulkhead
- b) Offside and nearside covings, full length of both saloons
- c) Header panels, both saloons
- d) Staircase front, rear and side bulkheads, both saloons, and under stairs area
- e) All power door gear compartments



- f) Front, nearside and rear route/destination display equipment
- g) Engine compartment
- h) Antenna location (forward roof area)
- i) Seat stanchions/grab poles
- j) Any further specific locations to be identified

It shall be possible to feed and draw cables to and between these areas without the need for extensive dismantling of the coachwork, and definitely without the need for any cutting, drilling or other invasive surgery. This shall be achieved by ensuring that all voids/channels are contiguous and can be accessed easily by the provision of appropriate access points.

Access points shall be provided at all junctions and changes of direction.

Where a cable is secured to a fixing point the fixing point must be accessible such that the method used to secure the cable can be easily removed freeing the cable.

Cables for all the operator equipment fitted shall be separate and clearly identifiable.

Cables shall be installed so that when being removed they do not snag existing cables or equipment.

The upper and lower deck coving voids shall have channels on the left and right hand side so that it is possible to freely run cables the full length of the roof. Access shall be provided at regular intervals to facilitate this.

The channels in the roof space in the upper and lower deck shall be connected by channels running across the bus from left to right. These cross bus channels shall be at the front and rear of the bus. Access shall be provided at regular intervals to facilitate the use of these.

There shall be fixing points to fix the cables throughout the length of all channels. The fixing points shall be spaced at distances of approx. 200mm.

It shall be possible to run cables from the equipment enclosure to the lower deck roof space on the left and right hand side. It will be acceptable for the cables to follow the same route to the roof space and then one cable can use the cross bus channelling to access the other side. Access shall be provided at regular intervals to facilitate the use of these.

It shall be possible to run cables from the equipment enclosure to the upper deck roof space on the left and right hand side. If practical the cables may follow the same route to the roof space and then one cable can use the cross bus channelling to access the other side. Access shall be provided at regular intervals to facilitate the use of these.

All access panels used to facilitate the above shall have fastenings designed for the purpose of being removed and refitted by authorised personnel. At other times the panel shall remain securely in position.

All access panel fastenings shall be captive.

In the event access is restricted in areas such as the bodywork to the side of the upper deck front screen and the stairwell, conduit should be provided.



Where conduit is required at the upper deck front screen 2 pieces of conduit shall be provided, one will branch and run towards the front screen the other will run towards the rear of the bus.

Where conduit is required and the path is convoluted with tight bends conduit shall be used in multiple straight lengths.

All cable routes, channels and ducts shall have access points at regular intervals, and at all junctions and changes of direction, to facilitate the insertion and removal of cables.

Where it is not possible to have intermediate access points the minimum bend radius of the conduit shall be as advised by the supplier of the conduit.

All conduit used shall have a smooth internal wall allowing cables to be pushed easily through.

Where conduit is used it shall be a sufficiently long to be accessible at each end to allow easy access

The conduit used shall be a bright colour to allow it to stand out from the conduit used for the bus systems.

If there is a restriction to the dimensions of the conduit due to for instance the body work then the largest dimensions possible shall be used. As an absolute minimum this shall allow an un-terminated Ethernet cable to be drawn through when all cables using the conduit are present.

Where a cable goes through a bulkhead the cable should be secured in such a way that the integrity of the bulkhead is maintained. The method used should allow for additional cables to be fitted.

4 Enclosure Specification

An enclosure with a minimum size of at 50dm³ (1/20 m³) approx. 370mm x 370mm x 370mm shall be provided.

Access to the enclosure shall be provided via secure panels or doors.

The access doors or panels shall be situated to allow ease of access to installation and maintenance personnel.



Attachment 5: Driver-Passenger Two-Way Communication Protocol

1 Introduction

This attachment provides specifications, test methods and test values for Driver-Passenger two-way communication systems system as required by the main specification document.

The two-way communication system should allow adequate communication between driver and passenger, regardless of accessibility needs. This protocol sets out the design, feature and performance requirements in order to implement such a system for use on buses within the TfL fleet.

For full understanding of this Attachment it should be read in conjunction with the New Bus Specification, Section 4.2.1.

2 Scope

These requirements apply to all new buses intended for service under contract to TfL that are passenger vehicles with a maximum mass exceeding 5 tonnes and a capacity exceeding 22 passengers. The passenger vehicles will be capable of carrying seated but unrestrained occupants and standing occupants. Such vehicles are categorised in the Consolidated Resolution on the Construction of Vehicles (R.E.3) as M₃; Class I.

3 Normative References

The following normative documents, in whole or in part, are referenced in this document and are indispensable for its correct application. For dated references, only the edition cited applies. For undated references, the latest edition of the referenced document (including any amendments) applies.

- London Bus Services Limited New Bus Specification: Section 4.2.1
- London Bus Services Limited New Bus Specification: Section 6.4.1



4 General Requirements

The driver/passenger 2-way intercom system shall provide an enhanced amplification for both driver and passenger to achieve clear speech at the front entrance platform, and driver cab area.

The system activation shall be fully automatic and require no operation by the passenger.

The system shall incorporate: -

- Driver - Press to Talk button (PTT) - cab microphone – cab speaker
- Passenger - one or more microphones – one or more speakers
- Override function - to allow for driver instructions when doors are closed

Microphones shall be of the close-proximity directional type to ensure only conversations in the immediate area around the cab can be heard. Further development work is being undertaken in this area to refine microphone directionality if necessary.

Speakers shall be a minimum of 5 watts and similar in size and design to the current iBus speaker.

The system performance shall be such that it allows for comfortable speech levels at the platform area of those expected within a busy bus environment.

5 Passenger Platform Area

The system shall be installed such that it does not require passengers to speak directly into a mounted microphone for clear communications to take place.

The microphone shall be mounted at a height of not less than 2m measured from the platform floor, and angled, directed at the front entrance door.

The platform microphone shall be mounted to one of the following areas:

- The panelling above the cab door
- The roof
- To the side of the cab door.

The microphone should not be mounted on the cab door, frame or panels exposed to high vibration or shock levels.

The microphone range performance must be capable of providing good coverage, such that the driver is able to clearly hear a passenger speak when either standing or sitting (e.g. a wheelchair user) on the pavement/ground at the entrance door.

The speaker performance shall reproduce comfortable volume levels, clear speech and be mounted such that it provides good coverage to someone at the platform and is audible to someone either standing or sitting (e.g. a wheelchair user) on the pavement/ground at the entrance door.



6 Driver Cab

The driver PTT button and microphone shall wherever possible be mounted in a position and close proximity to the partition screen to encourage the driver to face passengers when communicating. Care must be taken with the layout to ensure an ergonomically design in consideration of reducing the driver's overall movement.

7 System Activation/ Deactivation

The system shall function as follows:

1. Activation/deactivation may either be automatic using front door open/closed signal or manually operated (driver PTT) as and when system is required. System functionality may be achieved with the use of one of more buttons.
2. Shall have a control logic capable of integration with CAN bus in order to receive activation/deactivation signals.
3. When the front passenger doors are open, the system activation shall only be possible when the halt brake is engaged. The whole system must remain deactivated at all times while the halt brake is disengaged, unless the condition detailed below **(Point 4)** is true.
4. When the front passenger doors are closed, the system activation shall only be possible when the park brake is engaged. The whole system must remain deactivated at all times while the park brake is disengaged, unless the condition detailed above **(Point 3)** is true.
5. Where the system is fitted with an override function to allow for short operational conversation. The override function activation shall only be possible when the park brake is engaged. The override function must remain deactivated at all times while the park brake is disengaged.
6. The system once activated shall illuminate the PTT button to alert the driver that the system is live, and extinguished once doors are closed and system is deactivated. The passenger platform microphone or microphone housing must also incorporate a discrete LED to illuminate and function in the same way as the PTT.

8 Testing/Sound Level Settings

The volume control level for speakers and microphones shall be set during installation and commissioning. The volume control switch for adjustments shall be behind panelling requiring tools to remove. Volume adjustments shall be carried out by engineering staff only.

During testing and sign off special attention must be given to ensure there is no feedback or other interference present, both during system activation, and speech taking place. Further testing must also be carried out while other radio and driver announcement systems are being used to ensure no feedback or other interference is present.



The sound performance test's primary objective is to ensure a good sound quality output is achieved at the sound levels define in table below. All sound reproduction shall be of a good quality and must be free from system noise including audible artefacts such as clicks, gaps, hum, distortion effects or clipping.

Testing must be done with the driver/assistant facing in the direction of the platform area; to ensure the system is at optimal performance while the driver is facing customers during communications.

Please Note: (sound performance testing is to be further developed for future systems)

Testing shall be carried out using a class 2 calibrated sound level meter, as defined in IEC 61672, or equivalent device.

Sound meter measurement position	Test heights (meters)	Speaker Volume	Driver microphone test message 70db
Driver Cab	1.0m from seat cushion (mid height adjustment)	70db**	
Platform:- (i) centre (ii) step	1.2 } 1.45 } from floor 1.7 }	70-75db	70-75db
At entrance door	1.2 } 1.45 } * Note 1.7 }	70-75db	70-75db

*From pavement/ground bus at ride height

**From entrance door using height ranges

9 Compliance

The system control and management devices must be E marked for automotive use.

10 Development for New Buses

During the design and installation of the Driver-Passenger Two-Way 'Enhanced Sound' Intercom systems, TfL would like to introduce additional functionality and integration with other systems.

- a) The CCTV system to record and retain audio files at the driver cab/platform during system activation. (Where operators choose to install the optional functionality for recording/retention of audio files. The General Data Protection Regulations (GDPR) must be fully complied with as defined in the Specification for new buses section 6.4.1)
- b) The Induction Loop system at the driver cab/platform during system activation.
- c) The driver PA system



These system integrations will deliver additional driver and passenger safety benefits and accessibility enhancements. Integration will also reduce hardware duplication such as microphones and speakers to decrease clutter and improve driver cab ergonomics.

This specification sets out the minimum performance requirements. However, TfL would welcome suggestions from operators and OEMs on higher specifications standards and/or innovative solutions.

11 Training and Maintenance

Suitable training, operating instructions and maintenance materials shall be supplied to the bus operating company in order to ensure smooth and reliable performance of the system during in-service operating conditions.



Attachment 6: Standard for the Fire Retardant Properties of Materials

1 Introduction

This attachment specifies additional standards for materials with respects to their fire-retardant capability, over and above those required by Regulation.

For full understanding of this Attachment it should be read in conjunction with London Bus Services Limited New Bus Specification: Section 4.1

2 Scope

These requirements apply to all new buses intended for service under contract to TfL that are passenger vehicles with a maximum mass exceeding 5 tonnes and a capacity exceeding 22 passengers. The passenger vehicles will be capable of carrying seated but unrestrained occupants and standing occupants. Such vehicles are categorised in the Consolidated Resolution on the Construction of Vehicles (R.E.3) as M₃; Class I.

3 Normative References

The following normative documents, in whole or in part, are referenced in this document and are indispensable for the correct application of this test and assessment protocol. For dated references, only the edition cited applies. For undated references, the latest edition of the referenced document (including any amendments) applies.

- London Bus Services Limited New Bus Specification: Section 4.1
- UNECE Regulation 118-03 (Revision 02, Amendment 01) - Uniform Technical Prescriptions Concerning the Burning Behaviour of Materials Used in the Interior Construction of Certain Categories of Motor Vehicles.
- BS5852 – Methods of test for the assessment of the ignitibility of upholstered seating by smouldering and flaming ignition sources.
- ECE Regulation 100-R02 – Uniform Provisions Concerning the Approval of Vehicles with Regard to Specific Requirements for the Electric Power Train.
- EN 1364: Part 2: 2018 - Fire resistance tests for non-load bearing elements (Part 2: Ceilings)



4 Requirements

4.1 Vehicle Body Components

Each OEM must verify that all components of their products meet the technical requirements of UNECE Regulation 118-03 (Revision 02, Amendment 01). This will apply to Category M3, Class I vehicles via any approval route. OEMs will be expected to demonstrate that adequate arrangements are in place to ensure that subsequent products continue to meet and conform to the approved type and to monitor these arrangements to be effective during the life of the approval.

For vehicles fitted with an electric powertrain, the UNECE Regulation 118-03 (Revision 02, Amendment 01) definition of “Engine compartment” (section 2.3) shall in addition include any compartment that contains more of the following electric drivetrain components, with the exception of the condition described in Section 4.1.1.

- Rechargeable energy storage system used for traction energy
- DC-DC convertor
- Traction motor
- Power inverter
- Onboard charger
- Power electronics controller
- Air compressor

4.1.1 Rechargeable energy storage systems outside of the engine compartment.

Note: any compartment that contains only a Rechargeable energy storage system, it shall be governed by Section 4.1.2

4.1.2 Fire Barriers

In addition to complying with UNECE Regulation 118 rev 3, all bus body compartment walls/flooring that form a barrier between a rechargeable energy storage system used for traction energy and the passenger saloon, regardless of the material used, shall be such that the component or structure forms an impermeable fire and gas barrier, and must be certified to EN 1364-2; E15.

It shall be accepted that the following materials meet or exceed the EN 1364-2 E15 fire resistance performance classification, without the need for test certification. Any other alternative materials/construction require certification evidence to be submitted.

Material/construction	Performance
Steel sheet, 2mm thick	E60
Steel sheet, 2mm thick, with 50mm thick mineral fibre insulation	E60, I15
Aluminium sheet, 5 mm thick (non-insulated on cold face)	E15
Aluminium sheet, 3mm thick, with 30mm mineral fibre insulation on the hot face.	E30



4.2 Seat Assemblies

In addition to the requirements set out in UNECE Regulation 118-03 (Revision 02, Amendment 01), seat assemblies shall pass the criteria when tested to BS5852, Crib ignition source 7 and smouldering cigarette test; ignition source 0.

4.3 Rechargeable Energy Storage Systems (RESS)

Where the vehicle incorporates a Rechargeable Energy Storage Systems (RESS) as defined in ECE 100-R02 – Uniform Provisions Concerning the Approval of Vehicles with Regard to Specific Requirements for the Electric Power Train, then the RESS should meet the requirements of this Regulation via any type approval route.

From **September 2024**, all vehicle Rechargeable Energy Storage Systems shall be meet and be certified to ECE 100-R03, via any type approval route.

4.4 Operational Requirements

The materials, or any treatment used to achieve the requirements, must be capable of achieving the required standard when suitably cleaned or maintained over the operational life of the bus.

4.5 Replacement Parts

Replacement parts supplied by the manufacturer must achieve, or exceed, the same fire-resistance ratings as that supplied originally.

4.6 Compliance

Vehicle manufacturers are required to provide an auditable self-certification evidence pack of compliance with requirements in sections 4.1 – 4.3, per each vehicle model. Evidence pack shall as a minimum include a bill of materials within scope of the requirements, and corresponding approval certification reference information. For model variants i.e. minor interior options or alternative vehicle lengths, an evidence pack only detailing changes from the full bill of materials evidence pack for that model is required.



Attachment 7: Wheelchair Floor Logo

1 Introduction

This document provides a description of the requirements for Floor Logo to be situated in the demarcated wheelchair area of a bus.

For full understanding of this Attachment it should be read in conjunction with the New Bus Specification, Section 7.

2 Scope

These requirements apply to all new buses intended for service under contract to TfL that are passenger vehicles with a maximum mass exceeding 5 tonnes and a capacity exceeding 22 passengers. The passenger vehicles will be capable of carrying seated but unrestrained occupants and standing occupants. Such vehicles are categorised in the Consolidated Resolution on the Construction of Vehicles (R.E.3) as M₃; Class I.

3 Purpose

The purpose of this document is to define the requirements for the Wheelchair Floor Logo.

4 Normative References

The following normative documents, in whole or in part, are referenced in this document and are indispensable for its correct application. For dated references, only the edition cited applies. For undated references, the latest edition of the referenced document (including any amendments) applies.

- London Bus Services Limited New Bus Specification: Section 7
- London Bus Services Limited New Bus Specification: Attachment 33 Slip Prevention Assessment Protocol
- London Bus Services Limited New Bus Specification: Attachment 33 Slip Prevention Guidance Notes

5 Wheelchair area floor covering

The wheelchair logo shall be incorporated into the floor covering which identifies the designated wheelchair area.

6 Dimension requirements

The wheelchair floor logo shall be of identical style to that shown in Figure 7_1 and to the dimensions as shown $\pm 10\%$ as shown in Figure 7_1.

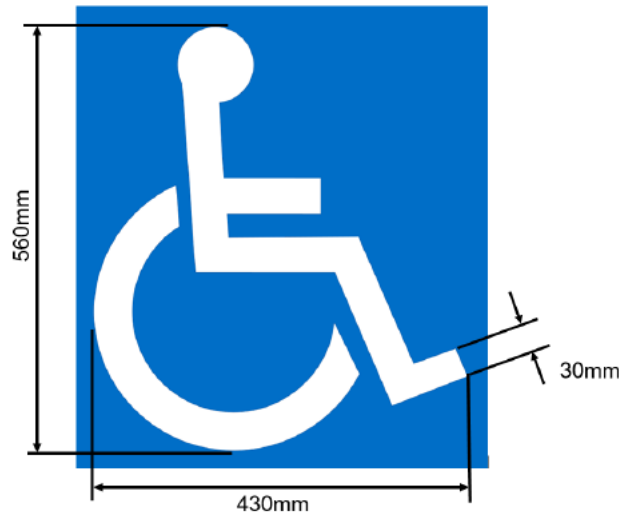

Figure 7_1 Wheelchair Logo

7 Colour requirements

The floor covering used across the whole Wheelchair bay, as shown by OEM's drawings, shall be coloured in Blue Ref PMS 300 (the same blue as the wheelchair notice). The wheelchair logo shall be coloured in plain White. Mild fleck in the base colours may be added to increase durability of the floor covering.

8 Slip prevention requirement

Material used for the floor logo must conform to the slip prevention assessment protocol and guidance notes found in Attachments 32 and 33 respectively.

9 Location and Orientation requirement

The logo in the wheelchair bay should always be positioned, readable by a person standing on the longitudinal centreline of the vehicle, in such a way to demonstrate the location and orientation which the wheelchair should be positioned. The logo must be located entirely within the bounds of the wheelchair bay, with positional requirements as detailed below and shown in figure 7_2:

- The longitudinal (vehicle X axis) centre line of the floor logo should be on the centre line of the vertical wheelchair back board $\pm 55\text{mm}$.
- The lateral (vehicle Y axis) centre line of the floor logo should be no more than 550mm from the wheelchair back board $\pm 55\text{mm}$.

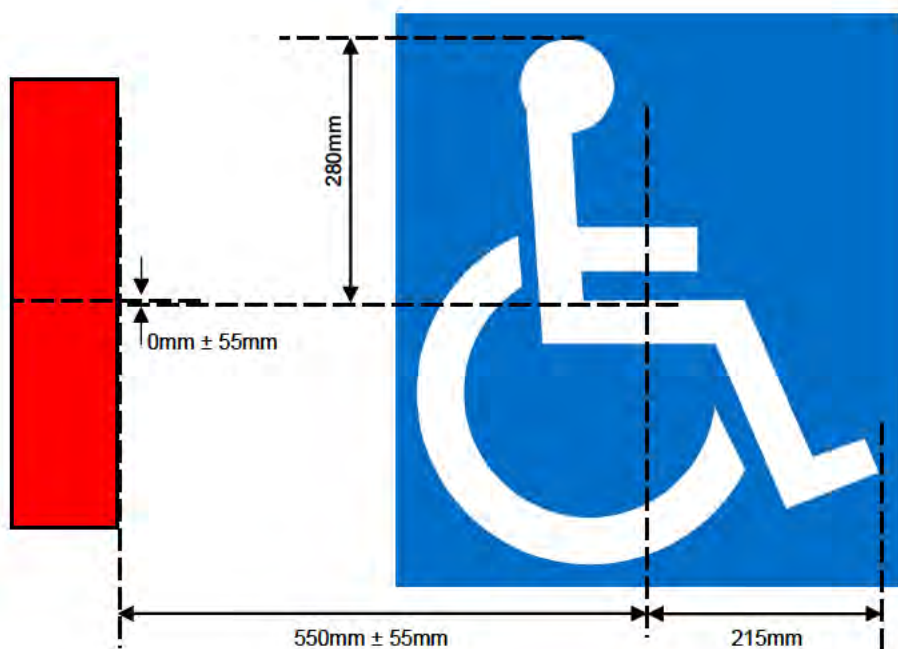

Figure 7_2 Wheelchair logo longitudinal and lateral location relative to back board



Attachment 8: Staircase Handrail Layout

1 Introduction

This document provides a description of the requirements for Handrail layout to be situated by the staircase of a double-deck bus.

2 Scope

These requirements apply to all new double-deck buses intended for service under contract to TfL that are passenger vehicles with a maximum mass exceeding 5 tonnes and a capacity exceeding 22 passengers. The passenger vehicles will be capable of carrying seated but unrestrained occupants and standing occupants. Such vehicles are categorised in the Consolidated Resolution on the Construction of Vehicles (R.E.3) as M₃; Class I.

3 Purpose

The purpose of this document is to define the requirements for the Staircase Handrail Layout.

4 Normative References

The following normative documents, in whole or in part, are referenced in this document and are indispensable for its application. For dated references, only the edition cited applies. For undated references, the latest edition of the referenced document (including any amendments) applies.

- London Bus Services Limited New Bus Specification: Section 4.5.1 – 4.5.3

5 Dimension requirements

The size and layout of the staircase and handrail shall be as shown below, Figure 8_1. All positional dimensions given shall be achieved within a tolerance of $[\pm 10]$ mm. (Tolerance applies to position/placement of handrail as shown in Figure only. Any other dimensions, such as handrail diameter, should be separately assessed as appropriate).

A straight hand pole at first joint from top of staircase will also be acceptable.

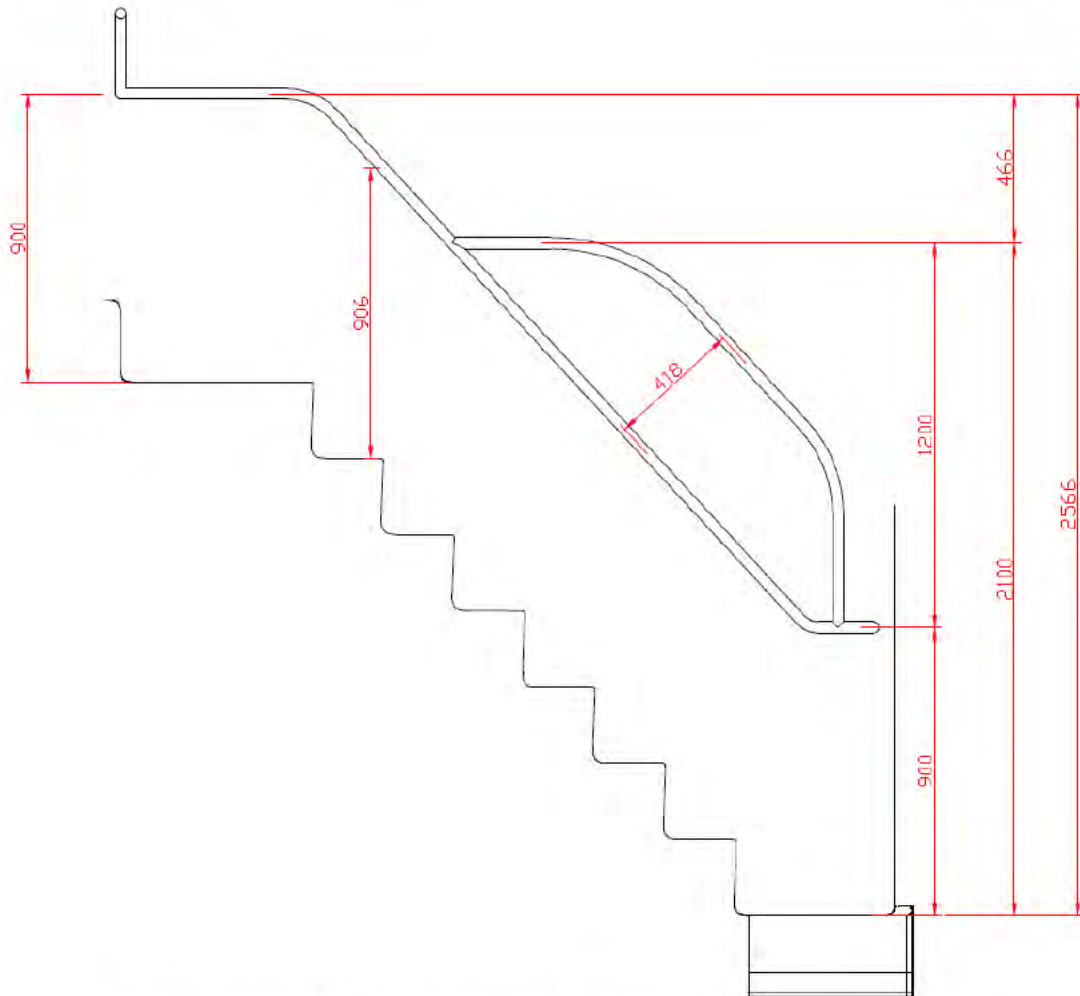

Figure 8_1: Staircase handrail dimensions given in mm

6 Handrail construction and arrangement

- All handrails must be securely fixed to body structure.
- Open joints or butt / sharp ends to rails are not acceptable.
- No potential hand traps shall be permitted.
- Continuous rails are the preferred arrangement.
- Rails must be of a continuous profile throughout.



Attachment 9: Heating Ventilation and Air Conditioning (HVAC)

1 Introduction

This attachment provides specifications, test methods and limit values for the HVAC system as required by the main specification document.

The HVAC system shall keep the bus cab and saloon at a comfortable temperature throughout the day and year. This specification sets out a controlled test; however, the HVAC system shall work over the entire operational ambient temperature range of the vehicle.

For full understanding of this Attachment, it should be read in conjunction with the New Bus Specification, Section 8.3.

2 Scope

This protocol applies to all new buses intended for service under contract to TfL that are passenger vehicles with a maximum mass exceeding 5 tonnes and a capacity exceeding 22 passengers. Vehicles shall be capable of carrying unstrained seated and standing passengers. Such vehicles are categorised in the Consolidated Resolution on the Construction of Vehicles (R.E.3) as M₃; Class I.

3 Purpose

The objective of this testing is to validate all parts of the bus HVAC system performance for all vehicles.

The test shall be performed on a whole vehicle which meets the TfL specification and is fitted with all equipment necessary for operation in London, excluding iBus and ticketing equipment.

4 Normative references

The following normative documents, in whole or in part, are referenced in this document and are indispensable for the correct application of this test and assessment protocol. For dated references, only the edition cited applies. For undated references, the latest edition of the referenced document (including any amendments) applies.

- London Bus Service Limited New Bus Specification Section 8.3



5 Definitions

For the purpose of this Protocol:

- **AA: Approval Authority** – The body within TfL that certifies that a bus is approved for use in the TfL fleet and assigns its score under the bus safety standard for use in procurement processes.
- **DCAB: Driver Cab** – The compartment where driver would perform the driving duty as enclosed by the assault screen.
- **OEM: Original Equipment Manufacturer** – The company responsible for the manufacture of a completed bus, delivered to a bus operator.
- **TS / Test Service** – The organisation undertaking the testing and certifying the results submitted to the Approval Authority.
- **VUT: Vehicle Under Test** – A vehicle that is being tested to this protocol.

6 General Requirements

The Test Service is designated by TfL to ensure comparative standards and quality of testing is achieved.

OEMs and / or bus operators are permitted to be present during testing but are not permitted to interfere with or adjust the bus settings after the start of any particular test, without full written agreement of the Test Service and TfL. All adjustments will be noted by the Test Service, adjustments prior to the start of a test are permitted and are to be noted.

During the heating and cooling tests:

- Door operation cycles shall be automatic and set up appropriately by the OEM/bus operator such that doors are opened every 90 seconds for a period of 10 seconds before closing.
- Both relative external and internal relative humidity shall be monitored and recorded. These values are required to conform to the passenger comfort limits set out in the specification:
 - relative humidity shall not exceed a maximum of 50% when interior temperatures are between 30°C to 40°C
 - relative humidity shall not exceed 70% when bus interior temperatures are between 0°C and 24°C
 - between 25°C and 29°C the relative humidity may linearly decrease within limits shown in figure 9_1:

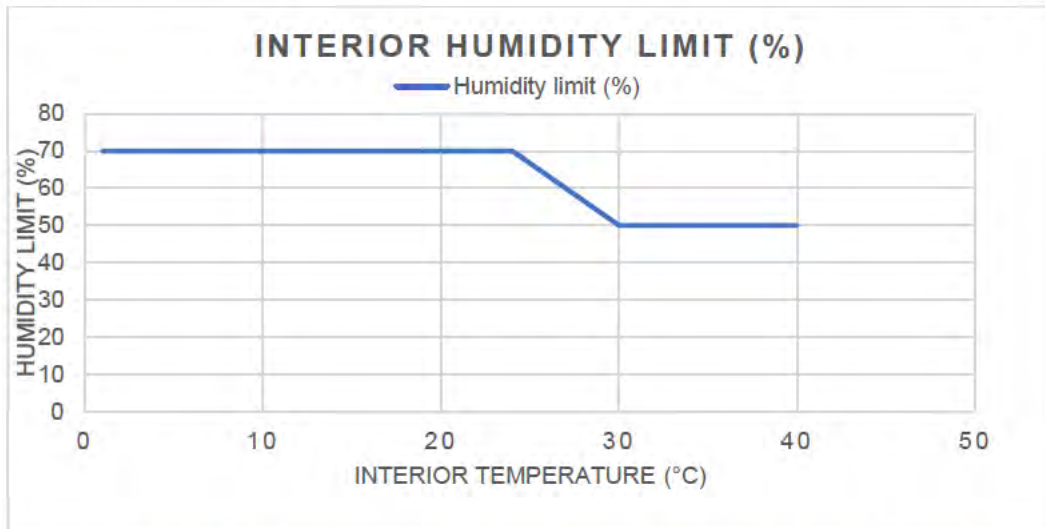

Figure 9_1: Air humidity as a function of the interior temperature

- Within an ambient temperature range of -3°C to 17°C there shall only be heating and between 25°C to 35°C there shall only be cooling. Between 17°C to 25°C ambient temperature, no heating or cooling is necessary as long as saloon temperatures are maintained between as per Figure 9_2.
- Continuous operation shall be ensured up to 45°C (ambient). Above 35°C (ambient), the system may operate with a permissible derating, but shall reduce temperatures by ≥5°C in the passenger saloon.

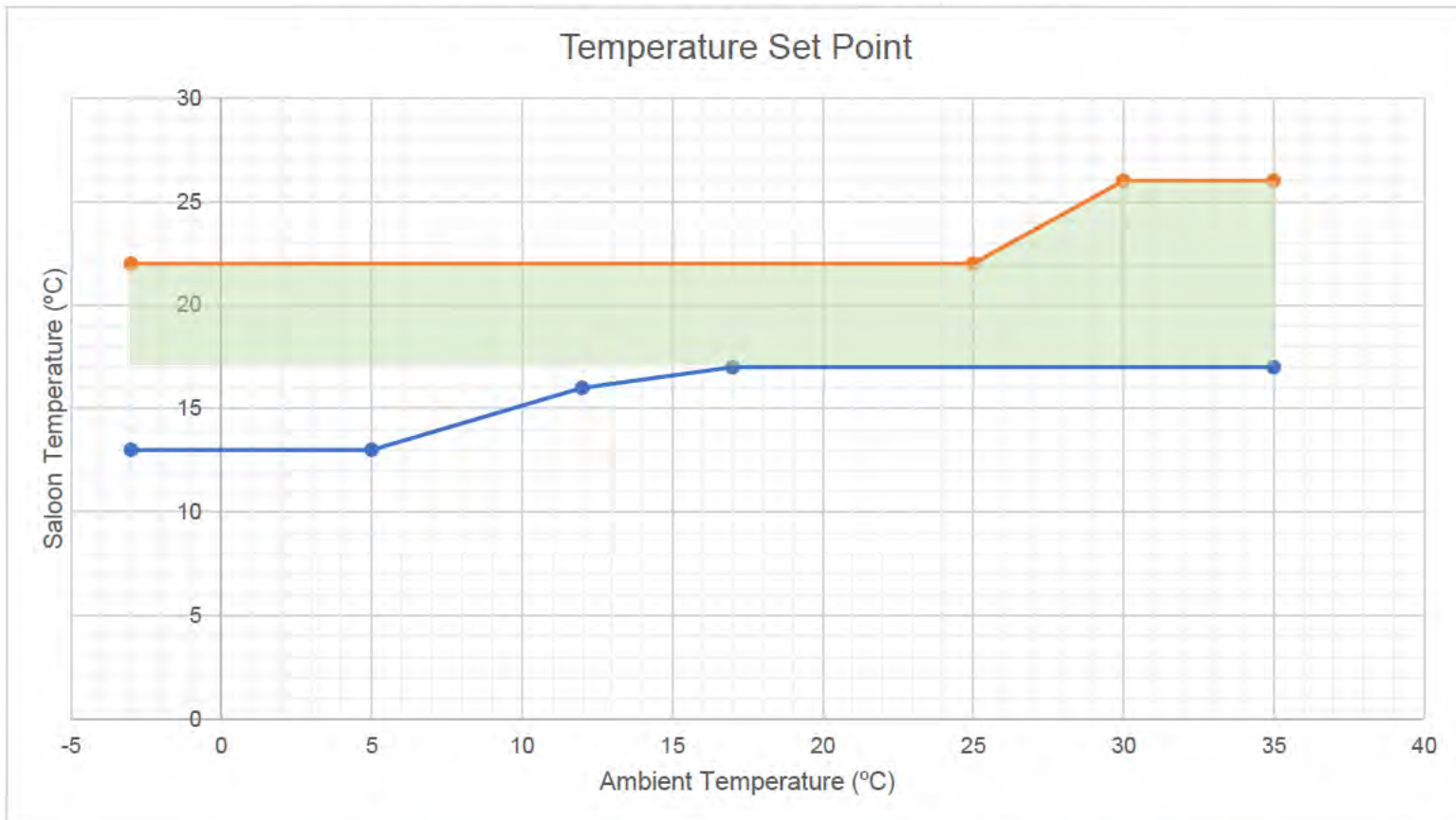

Figure 9_2: Temperature set points for heating and cooling limits



7 Instrumentation

The Test Service shall temporarily fit equipment as per listed per Table 9_1. All thermocouples shall be positioned along the longitudinal centreline of the vehicle unless otherwise specified.

Test	Item	DCAB/Upper deck/Lower deck	Location	Height
Heating and cooling	Thermocouple 1	DCAB	Head level	0.9m – 1.2m above floor level
	Thermocouple 2	DCAB	Foot level	0m – 0.3 m above floor level
	Thermocouple 3	Saloon lower deck	Behind DCAB at the centreline of the front axle	0.9m – 1.2m above floor level
	Thermocouple 4			0m – 0.3 m above floor level
	Thermocouple 5	Saloon lower deck	longitudinal centre of the vehicle's saloon length	0.9m – 1.2m above floor level
	Thermocouple 6			0m – 0.3 m above floor level
	Thermocouple 7	Saloon lower deck	1.0 m from the rearmost seating row	0.9m – 1.2m above floor level
	Thermocouple 8			0m – 0.3 m above floor level
	Thermocouple 9	Saloon upper deck	front row, nearside, align with the middle of seat base	0.9m – 1.2m above floor level
	Thermocouple 10			0m – 0.3 m above floor level
	Thermocouple 11	Saloon upper deck	7 th row, nearside, aligning with middle of the seat base	0.9m – 1.2m above floor level
	Thermocouple 12			0m – 0.3 m above floor level
	Thermocouple 13	Saloon upper deck	last row, nearside, align with middle of seat base	0.9m – 1.2m above floor level
	Thermocouple 14			0m – 0.3 m above floor level
	Thermocouple 15	Saloon lower deck	Centre of PID Zones 1	0.9m – 1.2m above floor level
	Thermocouple 16			0m – 0.3 m above floor level
	Thermocouple 17	Saloon lower deck	Centre of PID Zones 2	0.9m – 1.2m above floor level
	Thermocouple 18			0m – 0.3 m above floor level
	Thermocouple 19	Saloon upper deck	Centre of PID Zones 3	0.9m – 1.2m above floor level
	Thermocouple 20			0m – 0.3 m above floor level
Passenger draught speeds	Anemometer 1	Saloon lower deck	Centre of PID Zones 1	1.1m from the floor for a seated passenger and 1.6m from the floor for a passenger standing at a gangway
		Saloon lower deck	Centre of PID Zone 2	
		Saloon upper deck	Centre of PID Zone 3	
Heating and cooling	Humidity Probe/Monitor	DCAB, Saloon lower deck & upper deck	DCAB, PID Zones 1,2,3	Vertical centre between two thermocouples within zone



Heating and cooling	130W heaters	Saloon deck & lower upper deck	Evenly distributed across front – middle – rear (7 upper, 7 lower deck)	
Heating and cooling	Current Clamp	NA	High and Low Voltage inputs	

Table 9_1 Equipment Setup Details

The thermocouples shall be connected to a data logger capable of recording the temperature at each thermocouple at a minimum of 1 Hz.

Anemometers shall be used to measure air velocity (m/s).

8 Vehicle confirmation checklist

Prior to commencement of testing, confirmation from the Test Service that the vehicle is compliant to the following homologation requirements is necessary:

- Confirmation on which TfL Bus Safety Standard version the vehicle is designed to comply to
- Control logic shall demonstrate that:
 - The bus possesses an automatic, demand-controlled ventilation system that monitors CO₂ levels at all times for both the DCAB and passenger saloon.
 - Control logic shall demonstrate that CO₂ levels are automatically controlled to stay below 800ppm for the driver’s cab, and 1200ppm for saloon.
 - The control system calculates 3-minute rolling average CO₂ levels per deck for determination of saloon and DCAB CO₂ levels and ventilation control using all CO₂ sensors, demonstrated through CAN software.
 - A combined 3-minute rolling average temperature shall be calculated per deck and DCAB and used for the automatic thermostatic control, demonstrated through the CAN software.
- All HVAC systems shall be fitted with air filtration on the recirculation section of the system which meets standards listed in the “8.3.3.2 Air Filtration” section of the New Bus Specification. Documental evidence of filtration standard compliance shall be provided to the Test Service.
- The HVAC system for the bus shall keep the driver’s cab air supply and recirculation system separate to the passenger saloon system. The manufacturer to provide HVAC layout and schematic drawings to the Test Service for verification.
- Documental evidence shall be provided to record all side walls, floor and roof areas are fully insulated. Materials and thicknesses of the insulation shall be recorded in the test report.
- Saloon ventilation is independently controlled and delivered to both lower and upper deck where applicable.



- Manufacturer to provide documental evidence for glass design specification, this shall include evidence that at least 11% of the total surface side glass area (excluding door glass and destination glass) should be of the open hopper type, providing an open area air gap of not less than 3.5% of total glass area.

9 Test conditions

9.1 Pre-testing checklist

Prior to commencement of testing the Test Service shall check and record compliance to the following requirements:

- All buses shall possess a HVAC test switch in which:
 - Activation shall force the drivers cab and passenger saloon HVAC system to either 100% heat or 100% cooling output, depending upon selection.
 - The test mode selection shall be active for 10 minutes, after which time the system must automatically deactivate and return saloon to automatic thermostatic, and cab to driver control. The test switches shall be located within the passenger saloon, behind a panel that is easily accessible and removable with simple tools, such as behind a panel above a saloon door. The switches shall not be located within the driver's cab.
 - By pressing the test switch, air speeds are to be recorded during maximum cooling mode and shall measure not less than 0.5 m/s. These velocities are measured at the centre line of each seating location at a vertical distance of 1.1m from the floor, on the bus where there are vent openings.

9.1.1 Driver's cab (DCAB)

Driver's cab cooling must be capable of providing air speed to a minimum of 1m/s, with at least 5 driver selectable fan speed intervals. This shall be measured from a vertical distance of 1.1m from floor level relative to the centre of the driver's seating position.

Visual check/ measurement to ensure that within the driver's cab:

- Possesses a CO₂ sensor placed under the dashboard, away from the direction of blown air from any vent.
- Possesses air vents capable of providing cooling and heating (via a dial or similar), with direction of air flow manually controllable by the driver from these vents. The driver shall always have full control over whether or not the fresh air is heated or cooled (again via a dial or similar).
- Has a minimum of two of these vents positioned under the steering wheel, with the ability to direct air flow to the driver's foot level, and a minimum of two further vents positioned above, capable of directing air flow at the driver's arms and face.



- The driver can independently turn each vent on/off

9.1.2 Passenger saloon

Check bus design for compliance of window ventilation requirements as per “8.3.3.3 Window Ventilation” section of the HVAC specification including:

- Visual check for ventilation provision via opening (hopper vent) side windows.
- Visual check that on single and double deck buses, these windows are positioned as per the “8.3.2.5 Window Ventilation” section of the HVAC specification.

Visual check/measurement to ensure that within the passenger saloon:

- Heating shall be supplied at floor level (at a maximum vertical height of 30cm above floor level).
- Cooling shall be supplied from ceiling level (at a maximum vertical height of 30cm below the ceiling, where the ceiling is defined as the highest point of the interior of each applicable deck).
- Test Service shall check temperature sensors are positioned within the 3 PID zones stipulated in Figure 8_1 in Section 8.3 of New Bus Specification, positioned such that no direct blown air or convection heat is directed at the sensors.
- Test Service shall check CO₂ sensors shall be positioned in each of the three zones stipulated in Figure 8_1 in Section 8.3 of New Bus Specification in a tamper proof location.
- The external air inlets to the HVAC system for the saloon shall be greater than 2m from ground level.

9.2 Heating & Cooling Performance Test

9.2.1 Test Conditions

- In order to simulate the heating effect from passenger loading, 14 x 130 W heaters are to be evenly distributed across the front, middle and rear seats. For a double decker bus, 7 heaters are evenly distributed to the lower deck and another 7 to the upper deck evenly distributed across the front, middle and rear seats. This is to be turned on only when performing steps when door cycling is required, “Y”, in Table 9_2.
- A current clamp or any other means shall be used to provide power consumption for each step of the test (nominal voltages may be used for this purpose), current clamps if used shall also be connected to high voltage inputs.
- Where the test includes door cycling, both doors shall open for 10 seconds every 90 seconds for the entirety of the test section, as per figure 9_3. This shall be automatically operated as opposed to manual operation, set up by the OEM/bus operator.

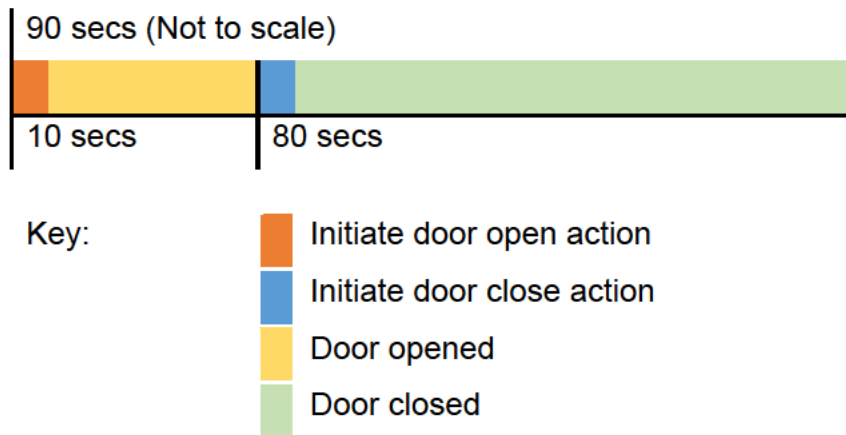

Figure 9_3: Test door cycle timeline

- The bus shall be powered on when the following preparatory checks have been completed:
 - The thermocouples, anemometers and humidity sensors are correctly positioned.
 - The data recorder is running, including the soak period.
 - Record and ensure the state of charge (SOC) of the battery is >90% at the start of test each day. SOC shall also be noted at the start and end of each step of the test. Non-essential equipment related to the test on the bus such as saloon lightings shall be switched off before the start of each step.
- The Test Service will produce a graph of the test showing the temperature recorded by each individual thermocouple (temperature against time). Ambient chamber temperature will also be included on each graph, along with interior and exterior relative humidity with battery SOC. A spreadsheet showing the results from each thermocouple and ambient chamber temperature will accompany the graphs.
- During vehicle soak, doors and windows should be kept open unless otherwise specified.
- During the Sweep Test (as below Table 9_2) vehicle idle shut down function shall be deactivated, either keeping the vehicle in Neutral Gear or by software change.
- During **Step 0** and **Step 7a**, graph of recorded temperatures with rate of temperature drop in the bus compartment shall be included in the test report for submission.



Step	Zone	Preparation	T _{chamber} (°C)/ Chamber Humidity	T _{saloon} (°C)/ Max. Bus Humidity	T _{driver} (°C)/ Max DCAB Humidity	Duration (mins)	Door cycle
Step 0: Test Chamber temperature set to 48°C for soaking. Soak for a duration of not less than 480 minutes. All doors and windows on the bus are to be closed during the soak period.							
0	Chamber	Chamber acclimatisation	48	--	--	≥480	N
Step 1: Test Chamber temperature set to 48°C then 45°C for the last 15minutes of soaking. Soak for a duration of 90 minutes. All doors and windows on the bus are to be opened during the soaking period. At the end of the soak time, all doors and windows to be closed.							
1a	Chamber	Chamber acclimatisation	48	--	--	75	N
1b	Chamber	Chamber acclimatisation	45/ 70%	--	--	15	N
Step 2: Bus is powered ON. The Test Chamber remains at 45°C. Bus HVAC system shall automatically come on. Driver's Cab AC is switched on and temperature set to min and max fan speed. Duration for cooling is 60 minutes.							
2	Saloon	Saloon cooling	45/ 70%	40/ 50%	--	<u>60</u>	N
	DCAB	DCAB cooling	45/ 70%	--	35**/ 50%	25	N
Step 3: Test Chamber temperature set to 35°C for soaking, for a duration of 60 minutes. All doors and windows on the bus are to be opened during the soaking period. At the end of the soak time, all doors and windows to be closed.							
3a	Chamber	Chamber acclimatisation	35	--	--	45	N
3b	Chamber	Chamber acclimatisation	35/ 70%	--	--	15	N
Step 4: Bus is powered ON. The Test Chamber remains at 35°C. The HVAC system shall automatically come on. Driver's Cab AC is switched on and temperature set to min and max fan speed. Duration for cooling is 60 minutes.							
4	DCAB	DCAB cooling	35/ 70%	--	22/ <63%	60	N
	Saloon	Saloon cooling		26/ <63%	--		N
Step 5: Driver's cab AC is switched off. The bus maintains a minimum saloon temperature of 26°C for 15 minutes, while the Test Chamber is still at 35°C and door cycle process is conducted.							
5	Saloon	Maintain saloon temp	35/ 70%	26/ <63%	--	30	Y
Step 6: Test Chamber remains at 35°C. All doors and windows on the bus are to be opened until 22:00 of Day 1							
6	Saloon DCAB &	Bus soaked	35	--	--	Until 22:00 of Day 1	N
Step 7: Set chamber to -5°C and soak the bus for a minimum of 8 hours. All doors and windows on the bus are to be closed during this first soaking period. Then -5°C for 75 minutes and -3°C for 15 minutes. All doors and windows on the bus are to be opened during this second and third soaking period.							
7a	Saloon DCAB &	Bus soaked	-5	--	--	≥480	N
7b	Saloon DCAB &	Bus soaked	-5	--	--	75	N
7c	Saloon DCAB &	Bus soaked	-3	--	--	15	N
Step 8: Test Chamber remains -3°C. The HVAC system shall automatically come on. Driver's Cab heating mode to be set to max temperature and max fan speed. Duration for heating is 60 minutes.							
8	DCAB	Driver cab heating	-3	--	17*/ 70%	25	N
	Saloon	Saloon heating	-3	>13/ 70%	--	<u>60</u>	N
Step 9: Driver's cab HVAC is switched off. The bus maintains a minimum saloon temperature of 13°C for 30 minutes, while the Test Chamber is still at -3°C and door cycle process is conducted.							
9	Saloon	Maintain saloon temp	-3	>13/ 70%	--	30	Y



Step 10: Change the Test Chamber temperature to 15°C then to 12°C for the last 15 minutes of soaking. All doors and windows are to be opened during this time. Soak for a duration of 90 minutes. At the end of the test time all doors and windows are to be closed.

10a	Chamber	Chamber acclimatisation	15	--	--	75	N
10b	Chamber	Chamber acclimatisation	12/ 70%	--	--	15	N

Step 11: The passenger saloon HVAC system operates for 30 minutes with door cycle process conducted..

11	Saloon	Saloon heating	12/ 70%	16/ 70%	--	30	Y
----	--------	----------------	---------	---------	----	----	---

Step 12: Bus powered off. Change the Test Chamber temperature to 28°C then 25°C for the last 15 minutes of soaking. All doors and windows are to be opened during this time. Soak for a duration of 90 minutes. At the end of the test time all doors and window are to be closed.

12a	Chamber	Chamber acclimatisation	28	--	--	75	N
12b	Chamber	Chamber acclimatisation	25/ 70%	--	--	15	N

Step 13: Bus powered on. The passenger saloon HVAC system operates for 30 minutes with door cycle process conducted.

13	Saloon	Saloon cooling	25	22/ 70%	--	30	Y
----	--------	----------------	----	---------	----	----	---

Step 14: Bus powered off. Change the Test Chamber temperature to 33°C then 30°C for the last 15 minutes of soaking. All doors and windows are to be opened during this time. Soak for a duration of 90 minutes. At the end of the test time all doors and windows are to be closed.

14a	Chamber	Chamber acclimatisation	33	--	--	75	N
14b	Chamber	Chamber acclimatisation	30/ 70%	--	--	15	N

Step 15: Bus powered on. The passenger saloon HVAC system operates for a duration of 30 minutes with door cycle process conducted..

15	Saloon	Saloon cooling	30/ 70%	26/ <63%	--	30	Y
----	--------	----------------	---------	----------	----	----	---

Table 9_2: Testing Conditions (sweep)

* DCAB Set to Max Temp and Max Fan Speed.

** DCAB set to Air Conditioning (AC) ON with Min Temp and Max Fan Speed.

9.2.2 Pass/Fail Criteria

- A $\pm 3^{\circ}\text{C}$ test tolerance is to be applied to climate chamber temperatures
- A $\pm 1^{\circ}\text{C}$ test tolerance is to be applied to all interior specification target temperatures.
- During time of temperature sweep testing as per table 9_2, if the temperature of any sensor drops below the required temperature with a tolerance of ($\pm 1^{\circ}\text{C}$) the step can be repeated once.
- Tolerance for interior humidity ($\pm 5\%$)
- All direct contactable vent surfaces (lower level heating) and air flow temperatures shall not exceed 45°C .
- Inside the passenger saloon excluding DCAB and front windscreen demister outlets, air speeds are to be recorded and shall not exceed the maximum of 5m/s.
- Temperature differentials shall remain as low as possible with:



- a maximum allowable deviation of $\pm 5^{\circ}\text{C}$ across each deck, in the longitudinal axis.
- a maximum allowable deviation of $+3^{\circ}\text{C}$ from foot level to head level of each deck when heating, in the transverse axis.

9.2.3 Demist test

[This part of the test is currently under review]

9.2.4 Ventilation test

Both the driver's cab and passenger saloon HVAC systems shall be switched on to provide maximum fresh air.

Air speeds at all saloon and DCAB vent outlets shall be measured and recorded. Data collected shall be used to calculate volume flow rate to demonstrate that ventilation meets the following requirements:

- Driver's cab ventilation is capable of providing 10L/s of fresh air.
- Inside the passenger saloon, for a bus at maximum occupancy, saloon ventilation shall be capable of providing a minimum of at least 15m³/h per person of fresh air for a fully loaded vehicle.



Attachment 10: Destination Display

Output

For full understanding of this Attachment it should be read in conjunction with London Bus Services Limited New Bus Specification: Section 10

**Off Side Front
Ultimate Destination**

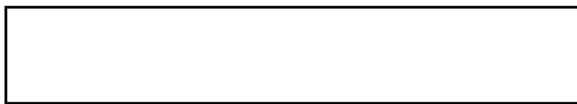

**1160mm x 330mm
Sight Size**

**Near Side Front
Route Number**



**450mm x 330mm
Sight Size**

Near Side Route Number and Destination

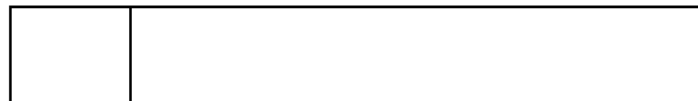

**Route Number Forward
270mm x 210mm
Sight Size**

**Side Destination Rearward
687mm x 210mm
Sight Size**

**Rear
Route Number**

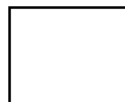

**450mm x 330mm
Sight Size**



Attachment 11: CCTV

1 Introduction

This attachment provides hardware, functionality and performance requirements for CCTV systems fitted to buses entering the LBSL fleet as laid out in the main specification.

For full understanding of this Attachment it should be read in conjunction with the New Bus Vehicle Specification, Sections 4.3.5.1 and 6.4.1.

2 Scope

This protocol applies to all new buses intended for service under contract to TfL that are passenger vehicles with a maximum mass exceeding 5 tonnes and a capacity exceeding 22 passengers. The passenger vehicles will be capable of carrying seated but unrestrained occupants and standing occupants. Such vehicles are categorised the Consolidated Resolution on the Construction of Vehicles (R.E.3) as M₃; Class I.

3 Purpose

The objective of this Attachment is to detail the hardware and performance requirements for CCTV systems fitted to buses entering the LBSL fleet.

4 Normative references

The following normative documents, in whole or in part, are referenced in this document and are indispensable for the correct application of this test and assessment protocol. For dated references, only the edition cited applies. For undated references, the latest edition of the referenced document (including any amendments) applies.

- London Bus Service Limited New Bus Specification Section 4.3.5.1
- London Bus Service Limited New Bus Specification Section 6.4.1
- ONVIF™ Media Service Specification - Version 21.12
- ONVIF™ Media2 Service Specification - Version 21.12

5 Definitions

For the purpose of this Protocol:

- **AA: Approval Authority** – The Approval Authority is the body within TfL that certifies that a bus is approved for use in the TfL fleet and assigns its score under the bus safety standard for use in procurement processes
- **CCTV:**– Closed Circuit Television
- **NMEA** - National Marine Electronics Association



- **NVR:-** Network Video Recorder
- **LAN:** – Local Area Network
- **ONVIF:-** Open Network Video Interface Forum

6 General Specification

6.1 Connectivity

The NVR shall have the following interfaces:-

- A Local Area Network (LAN) interface, presented as Ethernet through an RJ45 connection.
- An integrated 4G/5G modem.

For the integrated Mobile Network modem, there is a preference that this modem fits within the Network Video Recorder (NVR), thus minimising installation cost and footprint.

The LAN and modem interfaces shall be password protected and have multiple levels of access i.e. administration, user, read only.

The NVR's interface shall be ONVIF profile G compliant and accessible via the LAN or modem to allow full control of the NVR. The specification, protocols used and command strings will be provided to LBSL on request.

LBSL reserves the right to use these interfaces.

6.2 Function

- a) The image resolution shall be 720p or better, 720p will be set as a default.
- b) Each camera input shall be capable of recording at 25 frames per second at the maximum image size and highest image quality concurrently.
- c) The CCTV system shall have the flexibility to select the frame rate for each individual camera up to the maximum rate.
- d) The NVR shall support a minimum total global frame rate of 100 frames per second.
- e) The NVR shall support 16 camera inputs as a minimum.
- f) The NVR shall have an easily removable hard disc for external monitoring or ability to be downloaded via external connection.
- g) Bus data to be recorded on the disc drive
- h) Bus road speed taken from the GPS, foot brake application and traffic Indicator "left and right" recorded with date and time identification
- i) Recording not to be displayed on driver's cab monitor or passenger monitor
- j) All images shall be watermarked or equivalent.



- k) The NVR shall have the capability to record an audio input from two or more microphones.
- l) The NVR shall use a high compression video codec to encode and store the image data on the hard disk, this shall be the following:-
 - ITU-T H.264 that meets the requirements of:
 - <https://www.onvif.org/specs/srv/media/ONVIF-Media-Service-Spec.pdf>
 - <https://www.onvif.org/specs/srv/media/ONVIF-Media2-Service-Spec.pdf>

Note: the use of any other codecs not referenced in ONVIF is prohibited

The NVR shall be able to dual stream i.e. code an image at different rates such that a low rate can be streamed for Live CCTV and a higher rate recorded to disk for collection later. This shall be possible with the codec listed in 6.2L above.

The NVR shall be Live Closed Circuit Television (CCTV) capable so that should LBSL decide to rollout Live CCTV in the future the NVR will support this, more specifically:-

- The NVR shall have the capability to stream video through either of the interfaces, LAN and modem, to a control and management system developed for the solution.
- Live streaming shall be ONVIF [Profile S](#) or [Profile T](#) compliant
- The system shall have a documented interface from the control and management system that is made available to TfL for use in a potential Central CCTV Control and Management system.

The system's control and management system shall be able to:-

- Manage the video stream i.e. start/stop, pause, Fast Forward, Rewind during the event etc.
- Select the camera required.
- Select multiple cameras in thumb nail form.
- Manage the parameters that control the quality of the video stream.
- Perform System Administration and Operations and Maintenance functions.

The unit shall have an NMEA compatible Global Positioning System (GPS) interface.

The system clock shall have a resolution of 1 second and the time will be maintained to an accurate to +/- 10 seconds

6.3 Diagnostic Interface

The unit shall have the TfL diagnostic interface implemented and approved for use with iBus.

The LAN interface of the NVR will be made available to LBSL for diagnostics and other uses agreed at a later date.

6.4 Cameras



- All cameras shall be digital, ONVIF Profile S or Profile T compliant, and antiglare
- The cameras used shall be high quality colour 720p or better with day/night or low light capability
- The camera shall have an SNR of equal or greater than 50 dB in colour
- The camera shall support a mini ambient light level in colour of 0.5 lux
- All cameras must be housed in a Vandal Resistant Dome or Concealed
- Wide angle lenses utilised where necessary to improve vision coverage as identified on Bus type layout drawings submitted for TfL review and upload to the TfL BVS Database

6.5 Displays

The displays shall be LCD colour monitors.

All the displays shall show the time which is derived from the system radio adjusted clock.

The display shall be available in the following sizes:-

- 5" or equivalent suitable for locating in the drivers cab
- 15" or equivalent suitable for placing in the passenger area

6.6 Type Approval

The CCTV systems shall be designed to operate in a public transport environment. The operator will be required to supply type approval for:-

- E Mark
- Electromagnetic Compatibility
- Shock and Vibration
- Temperature
- Water ingress

Note: the CCTV system comprises the NVR, Cameras, intermediate cables, screens, connectors and any ancillary equipment.

The integrity of the type approval shall be maintained throughout the life of the contract.

The cameras should be rated as IP65 as a minimum.

7 Implementation

7.1 Installation

The CCTV systems shall be built in accordance with the TfL CCTV System Installation Guidelines. The key aspects of this are:-

- LBSL approval of the installation, the operator will present the installation instructions for approval prior to build.



- Documentation, the operator shall maintain the documentation for each build type and make them available for LBSL inspection.
- Co-existence with iBus, where possible the NVR shall be placed in the same location as the iBus unit.
- The NVRs shall be designed to work with the bus native power supply; any additional equipment necessary for this shall be considered part of the CCTV system.
- The NVRs shall remain on for 20 minutes once the ignition has been turned off.
- Installers of the CCTV system should be accredited to FCS 1362 (formally MPT 1362) or equivalent.

LBSL reserve the right to inspect the installation at source to ensure the standards are being applied appropriately.

7.2 Configuration

The image quality configuration parameters will be set to a TfL default as a minimum.

Each camera will be set to a frame rate as defined by TfL as shown in Table 11_1 below.

Location	Reference	Frame rate
Entrance/Exit Platform, wheelchair space and Passenger / Driver Interface	A1, A2	4
Rear of interior seated area	A3, C1	4
General passenger space	A4, B1, C2, C4	4
Forward facing to road	A5	4
Driver's Cab	A6	4
Stair Well	C3	4

Table 11_1 Camera frame rate parameter requirements

Note: The reference refers to the camera locations specified in section 7.3.

The operator will ensure that the parameters in Table 11_1 are maintained throughout the life of the contract.

TfL may choose to change this throughout the lifetime of the contract.

Note: The parameters will only be changed in exceptional circumstances.

The NVR will provide a minimum of 240 hours of storage space for each bus at the quality and frame rates defined above. The dimensioning of this should account for operating environment i.e. level of movement and lighting conditions.



If the operator uses the CCTV system beyond the minimum requirement set out here any additional CCTV resources that are required shall be supplied by the operator such that minimum requirements set out in this specification are met.

7.3 Camera Locations

The cameras shall be identified on the NVR system by the camera alpha numeric code as shown below (When two are cameras used to cover one location /1 or /2 should be added). Cameras must be located in accordance with the following guidelines for monitored areas with the area identified on channels as shown and as on Bus type layout drawings submitted for TfL review and upload to the TfL BVS Database.

All operator required additional cameras identified on subsequent channels as O13, O14 and above as necessary.

7.3.1 Mandatory All Buses (SD, DD)

- Entrance Platform and Passenger / Driver Interface (Channel 1)
- Exit Platform, Wheelchair Space and Deployed Ramp Area -Viewing Wheelchair Space only on Single Door Buses under 9m (Channel 2)
- Two cameras at rear of interior seated area looking forwards covering minimum rear five-way and last four rows of seats. Alternatively use of single camera with a wide-angle lens. (Channel 3 and 4 if two utilised)
- Between the centre door and the front of the bus which may be mounted either at the front looking rearwards or at the centre door looking forwards. (Channel 5)
- Forward facing to road ahead of bus (Channel 6)
- Interior Drivers Cab looking towards Drivers Signalling Window (Channel 7)
- Footwell camera as specified in Section 4.3.5.1 of the LBSL Bus Vehicle Specification (Channel 14)

7.3.2 Additional Mandatory All Single Deck Buses Over 10.4m length

- Centre door and the rear of the bus, looking rearwards (Channel 8)

7.3.3 Additional Mandatory All Double Deck Buses

- Two cameras at rear of upper saloon interior seated area looking forwards covering minimum rear five-way and last four rows of seats. Alternatively use of a single camera with a wide-angle lens. (Channel 9 and 10 if two utilised)
- Lower saloon between the centre door and the rear of the bus which may be mounted either at the rear looking forwards or at the centre door looking rearwards. (Channel 11)
- Top of stairwell looking downwards (Channel 12)



- Front of upper saloon interior seated area looking rearwards (Channel 13)

Note: Prior to building of the bus the operator shall confirm that the camera layout drawing has an approval reference (as submitted for TfL review and upload to the TfL BVS Database) given by LBSL. In the case where the layout does not meet the LBSL approved reference / guidelines the operator will be required to revise appropriately.

7.4 Displays

There shall be a display in the drivers cab, the display:-

- Shall be a 5" or equivalent LCD colour monitor.
- Suitably mounted in drivers cab area.
- Monitor to display the system time clock.

Shall, as default, display the exit platform and ramp deployment area when the centre exit door opens.

There shall be a display in the passenger area, the display:-

- Shall be a 15" or equivalent LCD colour monitor positioned in the lower saloon.
- Shall be suitably and securely mounted behind a vandal resistant protective screen.
- Monitor to display the system time clock

Shall be generally positioned so that the maximum number of passengers entering the bus will have the opportunity to view the screen when in one of the following positions:-

- Rearward exit door partition facing forwards
- Staircase to aisle fascia lower saloon facing inwards to centre of bus
- Staircase rearward partition facing up the staircase and viewable from lower saloon aisle at staircase entrance.
- Monitor will continuously cycle around all the cameras remaining on each camera for 5 seconds and end with an all camera view.
- Shall be installed in a manner consistent with the current iBus policy.

Use of displays on the upper deck is prohibited.

7.5 Security

The NVR and any additional equipment necessary for Live CCTV shall be enclosed in a secure, lockable and vandal proof enclosure that is located in accordance with the TfL design guides.



8 Operation

8.1 Performance

TfL will be providing a diagnostic and reporting capability utilising the current iBus system and will work with the NVR suppliers to ensure the NVR interface (Section 1.3) is developed and approved for use by TfL. The following is based on the use of this capability.

The performance of the CCTV system shall be 98% availability. For a system to be available the following is required:-

1. The NVR and ancillaries are fully operational
2. The NVR configuration is correct
3. The system time is correct to +/- 10 seconds
4. All but one of the cameras is working i.e. 1 camera failure is allowed without reducing the availability in the first week. For week 2 and onward the system is considered unavailable.

Availability is defined as:-

Total Time period – Total Hours unavailable during time period

Total Time Period

Time Period is the sum of all the operational hours of buses operating on contracts compliant with this specification during a period.

Total Hours unavailable during time period

Total Hours unavailable during a time period is the sum of all the unavailable hours of buses operating on contracts compliant with this specification during a period

Unavailable Hours are calculated from the time the fault status is made available to the operator to the time the system is fixed.

For a system to be considered as unavailable one or more of the criteria detailed in 1 - 4 above is not met.

The period is 28 days.

8.2 Maintenance

In the event of any errors or interruption of CCTV service the fault diagnosing procedure stipulated in the TfL-supplied CCTV User Guide shall be used. The operators maintain ownership and responsibility for repairing all CCTV equipment from Port 4 of the IBIS onwards.

8.3 Audit

The operator will be audited to ensure compliance against the required performance. The operator will be expected to maintain records of:-

- CCTV system inspections.
- Faults identified and date/time fixed.

The operator will provide Availability reports on request.



LBSL shall have the right to audit against the requirements in this specification to ensure traceability and accuracy of the data recorded.

8.4 Enforcement

Should the operator breach the availability targets then the operator shall put in place a recovery plan.

8.5 Provision of Data

The operator framework agreement contains all information related to the provision of data and should be reviewed as an overview of this Attachment.



Attachment 12: Exterior and Interior Notices

1 Introduction

This attachment provides hardware, functionality and performance requirements for Exterior and Interior Notices on buses entering the LBSL fleet as laid out in the main specification.

For full understanding of this Attachment it should be read in conjunction with the New Bus Vehicle Specification, Section 10, Specifically Section 10.3.

2 Scope

This protocol applies to all new buses intended for service under contract to TfL that are passenger vehicles with a maximum mass exceeding 5 tonnes and a capacity exceeding 22 passengers. The passenger vehicles will be capable of carrying seated but unrestrained occupants and standing occupants. Such vehicles are categorised the Consolidated Resolution on the Construction of Vehicles (R.E.3) as M₃; Class I.

3 Purpose

The objective of this Attachment is to detail the hardware and performance requirements for Exterior and Interior Notices on buses entering the LBSL fleet.

4 Normative references

The following normative documents, in whole or in part, are referenced in this document and are indispensable for the correct application of this test and assessment protocol. For dated references, only the edition cited applies. For undated references, the latest edition of the referenced document (including any amendments) applies.

- London Bus Service Limited New Bus Specification Section 10.3

5 Requirements

Exterior and interior notices are provided by LBSL as listed in the London Buses – Bus Graphics Standard (<http://content.tfl.gov.uk/london-buses-graphics-standard.pdf>), and must be fitted in the appropriate positions.

Please refer to the relevant section of the New Bus Vehicle Specification listed above for full details.

Attachment 13: Operator Codes and Fleet Number Identification

1 Operator Code Requirements

For full understanding of this Attachment it should be read in conjunction with London Bus Services Limited New Bus Specification: Section 10.3

The following operator codes must be used on the roof identification on the first line followed by the operator's fleet number on the second line. The codes must be fitted at the rear of the roof panel in the white panel area as shown in the diagram below

Operator	Code
Abellio	ABL
Arriva	ARL
Go Ahead Group	GAG
CT Plus	CTP
Metroline	MTG
Quality Line	QUL
Stagecoach	STC
London United	LUB
London Sovereign	SOV
Sullivan Buses	SVB
Tower Transit	TTO
University Bus	UNO

Typical Operator Code and Fleet Number Arrangement



Figure 13_1 Rear of Vehicle

- a) All Characters shall be in New Johnston Bold font
- b) Characters shall be in Matt Black cut out vinyl
- c) Characters shall be 350mm in height



Attachment 14: Free Issued Equipment

1 Introduction

This attachment provides hardware, functionality and performance requirements for Free Issued Equipment fitted to buses entering the LBSL fleet as laid out in the main specification

For full understanding of this Attachment it should be read in conjunction with the New Bus Vehicle Specification, Sections 6.4.3 and 6.4.4 respectively.

2 Scope

This protocol applies to all new buses intended for service under contract to TfL that are passenger vehicles with a maximum mass exceeding 5 tonnes and a capacity exceeding 22 passengers. The passenger vehicles will be capable of carrying seated but unrestrained occupants and standing occupants. Such vehicles are categorised the Consolidated Resolution on the Construction of Vehicles (R.E.3) as M₃; Class I.

3 Purpose

The objective of this Attachment is to detail the installation and hardware requirements for free issued equipment systems fitted to buses entering the LBSL fleet.

4 Normative references

The following normative documents, in whole or in part, are referenced in this document and are indispensable for the correct application of this test and assessment protocol. For dated references, only the edition cited applies. For undated references, the latest edition of the referenced document (including any amendments) applies.

- London Bus Service Limited New Bus Specification Section 6.4.3
- London Bus Service Limited New Bus Specification Section 6.4.4

5 Definitions

For the purpose of this Protocol:

- **AA: Approval Authority** – The Approval Authority is the body within TfL that certifies that a bus is approved for use in the TfL fleet and assigns its score under the bus safety standard for use in procurement processes
- **OEM: Original Equipment Manufacturer** – The company responsible for the manufacture of a completed bus, delivered to a bus operator



6 Free Issued Equipment

Provision must be made for the following free issue equipment to be installed in an approved package of arrangement and quality, as agreed between LBSL and each OEM.

6.1 iBus Equipment

The approved package of installation must consider the free issue iBus equipment as an integral part of the vehicles design. Particular consideration must be given to the practical requirements of maintaining the free issue equipment during the lifetime of the vehicle whilst in service on London Buses contracted routes.

For full details of the installation principles recommended please refer to the generic 'iBus Installation Manual' (**Document Ref: LBSL Equipment for new buses Installation manual BHN01 170970V18**) which has been issued to all OEMs. A copy of the 'iBus Installation Manual' is available on the Hyperion server to all bus operators.

The method of connecting iBus to the required inputs from the vehicle including power, door signal and odometer will be via automotive connectors at three converged points within the main iBus equipment compartment.

The connectors for iBus inputs at the converged points are as follows:

- 15 Way Connector
- 9 Way Connector
- 9 Way Connector



Part List – iBus Free Issue Equipment

PART NO.	DESCRIPTION	QTY/COMMENTS
UK-WRIGHT-VOL-CH	CONTI CABLE KITT	1 per vehicle - see breakdown below
TTS-0820-1009	EME CABLE KITT 6M	1 per vehicle - see breakdown below
TTS-0820-2157-XXX	MDT CABLE	1
TTS-0820-2191-B010	TRS CABLE	1
TTS-0820-2218-XXX	OBNSS CABLE - POWER	1 for Single Deck / 2 for Double Deck
TTS-0820-2219-XXX	OBNSS CABLE - DATA	1 for Single Deck / 2 for Double Deck
TTS-0967-0180	DC/DC MPT CABLE	1
TTS-0807-0003-D	TRS	1
TTS-0807-0004	IBIS UNIT	1
TTS-0919-0404	MPT RADIO	1
TTS-0919-0586	DC /DC CONVERTER	1
TTS-0945-0090	LOUDSPEAKER GRILL	6 per deck
TTS-0945-0094	PASSENGER LOUDSPEAKER	6 per deck
TTS-0945-0096	DRIVER SPEAKER	1
TTS-0945-0102	MICROPHONE	1
TTS-0709-0001-A	OBNSS DISPLAY SHORT - ADDRESS 1	Only one used per vehicle deck
TTS-0709-0002-A	OBNSS DISPLAY SHORT - ADDRESS 2	
TTS-0709-0003-A	OBNSS DISPLAY LONG - ADDRESS 1	
TTS-0709-0004-A	OBNSS DISPLAY LONG - ADDRESS 2	
TTS-0961-0475	FOOTSWITCH	1
TTS-0964-0476	FOOTSWITCH HOUSING	1
TTS-0945-0113	2 STUD ANTENNA	1
TTS-0945-0111	1 STUD ANTENNA WITH CLIP	1
TTS-0919-0418	TLP RADIO	1
TTS-0803-0012-A	MDT DISPLAY	1
TTS-0803-1516	MDT BRACKET - 90 DEGREE ANGLE	Only one used per bus/bus type
TTS-0803-1519	MDT BRACKET - 60 DEGREE ANGLE	
TTS-0803-1506	MDT FLUSH BRACKET	
TTS-0807-0002	DONGLE	1
TTS-0807-1016	DONGLE COVER WITH DAMPER	1
TTS-0807-1021	TRS MOUNTING BRACKET	1
TTS-0945-0103	MICROPHONE BRACKET	1
UK-WRIGHT-VOL-CH	CONTI CABLE KITT	INCLUDES
UK-TTS-0027	VEHICLE TERMINAL BLOCK & CABLES (2MT, 1MT or 0.5MT)	1
TTS-0820-2152-XX	Cable 2 - TLP radio to IBIS	1 - Flexible lengths
TTS-0820-2153-XX	Cable 3 - MPT Radio to IBIS	1 - Flexible lengths
TTS-0820-2154-XX	Cable 4 - Driver Mic to IBIS	1 - Flexible lengths



TTS-0820-2155-XX	Cable 5 - Ticket Machine to IBIS	1 - Flexible lengths
TTS-0967-0457-XX	CABLE 30 PERMANENT POWER CABLE	1 - Flexible lengths
TTS-0967-0438-XX	CABLE 32 IGNITION CABLE - NOT REQUIRED	1 - Flexible lengths
TTS-0967-0457-XX	CABLE 35- DRIVER SPEAKER CABLE	1 - Flexible lengths
TTS-0967-0457-XX	CABLE 36-PASS SPEAKER CABLE	1 - Flexible lengths
TTS-0967-0438-XX	CABLE 37 - DOOR 1 CABLE	1 - Flexible lengths
TTS-0967-0438-XX	CABLE 38 - DOOR 2 CABLE	1 - Flexible lengths
TTS-0967-0438-XX	CABLE 40 - FOOTSWITCH	1 - Flexible lengths
TTS-0967-0438-XX	CABLE 41- VEHICLE STOPPING	1 - Flexible lengths
TTS-0967-0449-XX	CABLE 42 - ODO CABLE	1 - Flexible lengths
TTS-0967-0457-XX	CABLE 43 DC/DC CONVERTER CABLE (POWER)	1 - Flexible lengths
TTS-0967-0438-XX	CABLE 45 DC/DC CONVERTER CABLE (SWITCH)	1 - Flexible lengths
TTS-0820-1009	EME CABLE KITT (Flexible Lengths)	INCLUDES
TTS-0820-2192-XXX	CABLE ANTENNA UMTS SYSTEMKABEL 20	1 - Flexible lengths
TTS-0820-2193-XXX	CABLE GHP-WLAN SYSTEMKABEL 21	1 - Flexible lengths
TTS-0820-2194-XXX	CABLE GHP-GSM/GPRS SYSTEMKABEL 22	1 - Flexible lengths
TTS-0820-2195-XXX	CABLE GHP-GPS SYSTEMKABEL 23	1 - Flexible lengths
TTS-0820-2196-XXX	CABLE ANTENNA MPT RADIO SYSTEMKABEL 24	1 - Flexible lengths

The schedule of parts for installation components shown in this document and Volume 2 Annex C, of the framework agreement will be provided to the OEM and must be included by the operator in the bus manufacturing specification.

6.1.1 Electrical and Signal Interface for iBus

In addition to the Installation manual previously stated. The electrical and signal interface between the bus and iBus terminal block is to be via a 15-way connector, and interface between the iBus terminal block and OBNSS, DC converter and MPT radio is to be via 9-way connectors as shown in Figure 14_1 below. The remaining iBus peripherals connect directly to the IBIS unit via D-connectors.

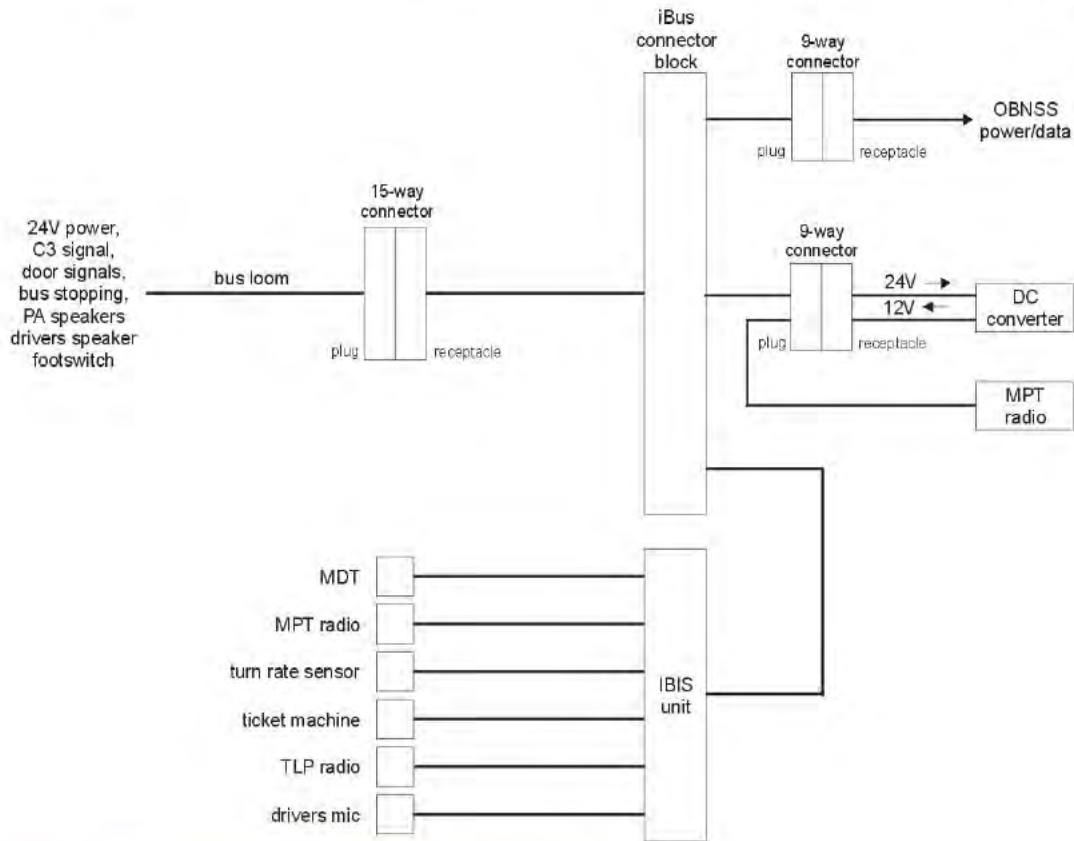

Figure 14_1: iBus Connection Schematic

The 15-way and 9-way connectors are manufactured by Tyco Electronics, details are as follows:

- | | | | |
|---------------------|----------------|-----|----------------|
| • 15-way plug | AMP 1-480710-0 | pin | AMP 1-350536-1 |
| • 15-way receptacle | AMP 1-480711-0 | pin | AMP 1-350218-1 |
| • 9-way plug | AMP 1-480672-0 | pin | AMP 1-350388-1 |
| • 9-way receptacle | AMP 1-480673-0 | pin | AMP 1-350389-1 |

Pin-outs of the connectors are shown in Figures 14_2-14_4 below.

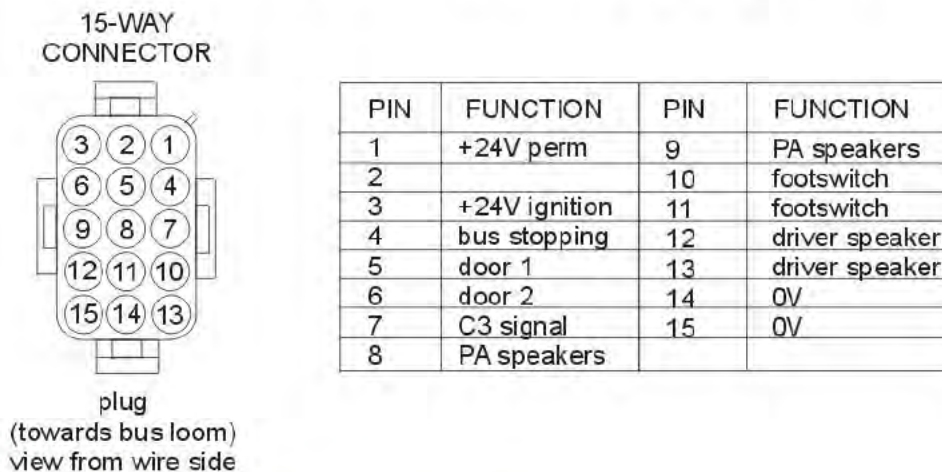

Figure 14_2: 15-way connector pin-outs

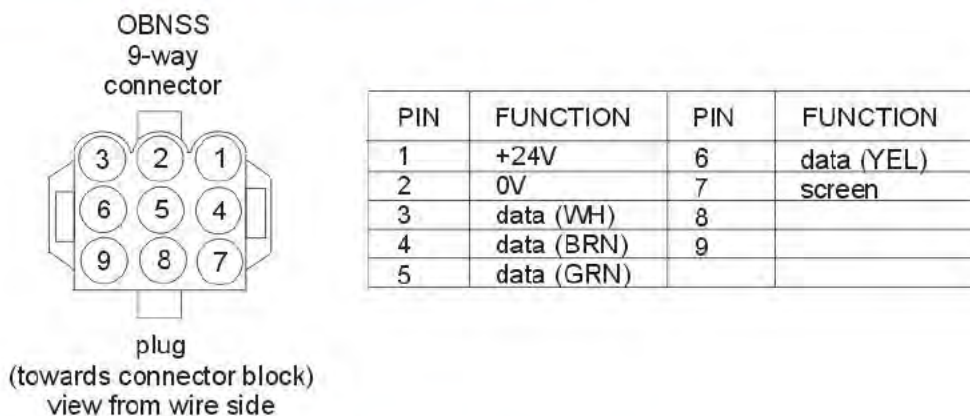

Figure 14_3: OBNSS 9-way connector pin-outs

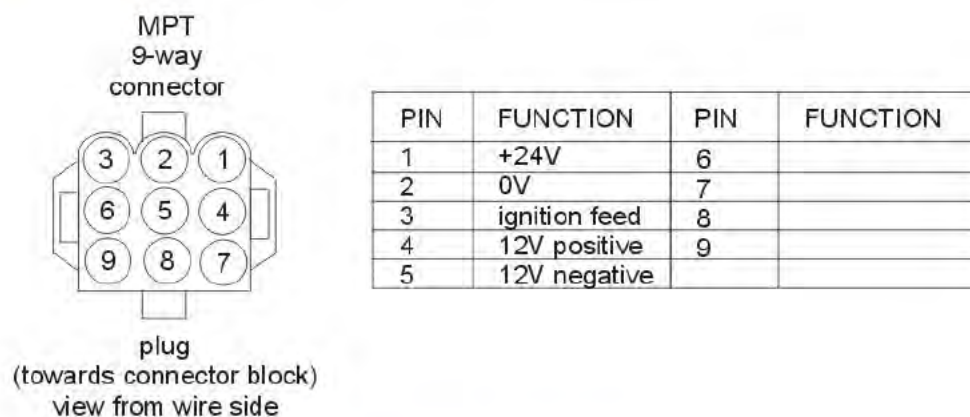

Figure 14_4: MPT 9-way connector pin-outs



External connections to the iBus connection block are shown in Figure 14_5 below.

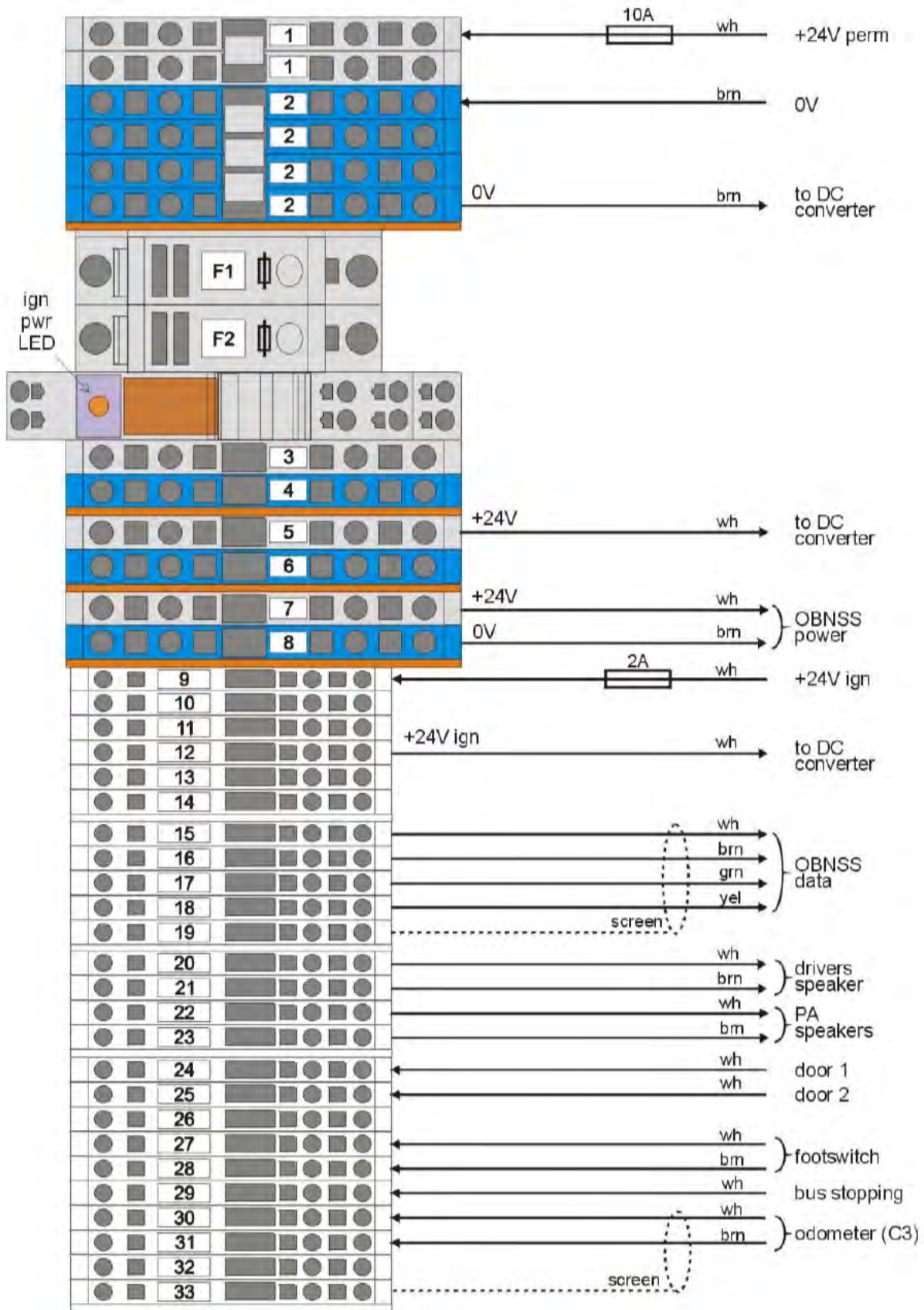

Figure 14_5: iBus connection block external connection pin-outs



6.2 Ticketing Equipment

Ticket Machine and base plate with smartcard readers will be installed after bus arrives in London

6.3 Bus Lane Enforcement Cameras

These are no longer required in a new bus installation.



Attachment 15: Advanced Emergency Braking (AEB) Assessment Protocol

1 Introduction

Advanced Emergency Braking (AEB) is a system that uses forward looking sensors such as Lidar, Radar, and/or Cameras to identify a risk of an imminent collision.

This document presents an assessment protocol and the underlying test procedures for objectively measuring the performance of Advanced Emergency Braking (AEB).

For full understanding of this Attachment it should be read in conjunction with the Attachment 16: Advanced Emergency Braking (AEB) Guidance Notes and New Bus Specification, Section 4.3.2.

2 Scope

This protocol applies to all new buses intended for service under contract to TfL that are passenger vehicles with a maximum mass exceeding 5 tonnes and a capacity exceeding 22 passengers. The passenger vehicles will be capable of carrying seated but unrestrained occupants and standing occupants. Such vehicles are categorised in the Consolidated Resolution on the Construction of Vehicles (R.E.3) as M₃; Class I.

3 Purpose

The purpose of the assessment is to test the ability of an AEB system fitted to a bus to avoid or mitigate collisions with other road users while minimising risks to occupants of the bus from unnecessary brake interventions. It is intended that the assessment generates objective data from a controlled and repeatable test to measure casualty reduction potential in the following collision types and where the bus is moving at a speed between 10 and 60 km/h:

- Frontal collisions with the rear of a stationary vehicle ahead
- Frontal collisions with a pedestrian crossing the road
- Frontal collisions with the rear of pedal cycles travelling in the same direction

The assessment also tests for false positive activation in a manoeuvre where the impact can easily be avoided by steering. Premature activation in situations where a pedestrian about to cross on a collision course with the vehicle and suddenly stops before entering the vehicles path is also assessed.

However, it should be noted that tests for true, false and premature positive activations represent only a small proportion of the real-world events that the systems will encounter in service. For example, it is expected that systems will react in collisions with the rear of any normal road vehicle in the lane ahead but only collisions with cars and bicycles are assessed. Similarly, the false and premature activation tests represent just two of thousands of real world scenarios that might challenge AEB systems. This protocol promotes the functionality that TfL see as



reasonably feasible and of most benefit to their objectives but, in isolation, it is insufficient to guarantee excellent system performance at all times in real world service. OEMs should always design systems to perform well in real world service and not only to do well in this test.

This test and assessment protocol may be applied in collaboration with an OEM as a validation of data they provide, or independently as part of a market surveillance activity or any other reason as defined by the Approval Authority.

4 Normative references

The following normative documents, in whole or in part, are referenced in this document and are indispensable for its correct application. For dated references, only the edition cited applies. For undated references, the latest edition of the referenced document (including any amendments) applies.

- For full understanding of this Attachment it should be read in conjunction with London Bus Services Limited New Bus Specification: Section 4.3.2
- For full understanding of this Attachment it should be read in conjunction with London Bus Services Limited New Bus Specification: Attachment 16 AEB Test Guidance Notes
- Directive 2007/46/EC of the European Parliament and of the Council establishing a framework for the approval of motor vehicles and their trailers, and of systems, components and separate technical units intended for such vehicles.
- Regulation (EU) 2018/858 of the European Parliament and of the Council of 30th May 2018 on the approval and market surveillance of motor vehicles and their trailers, and of systems, components and separate technical units intended for such vehicles, amending Regulations (EC) No 715/2007 and (EC) No 595/2009 and repealing Directive 2007/46/EC
- UNECE Regulation 107 Uniform provisions concerning the approval of category M₂ or M₃ vehicles with regard to their general construction
- Euro NCAP Test Protocol AEB VRU Systems Version 2.0.1 August 2017
- Euro NCAP Test Protocol AEB Systems Version 1.1 June 2015
- Euro NCAP Test Protocol AEB Systems Version 2.0.1 November 2017
- ISO 19206-2:2018 Road vehicles — Test devices for target vehicles, vulnerable road users and other objects, for assessment of active safety functions — Part 1: Requirements for passenger vehicle rear end targets.
- ISO 19206-2:2018 Road vehicles — Test devices for target vehicles, vulnerable road users and other objects, for assessment of active safety functions — Part 2: Requirements for pedestrian targets.
- ISO 19206-2:2018 Road vehicles — Test devices for target vehicles, vulnerable road users and other objects, for assessment of active safety functions — Part 3: Requirements for passenger vehicle 3-D targets.



- ISO 19206-4:2020 Road vehicles — Test devices for target vehicles, vulnerable road users and other objects, for assessment of active safety functions — Part 4: Requirements for bicyclist targets.
- ISO 15037-2 Road vehicles – Vehicle Dynamics Test Methods – Part 2: General conditions for heavy vehicles and buses



5 Definitions

For the purpose of this Protocol:

- **AEB: Advanced Emergency Braking** – Any system that is active at speeds of 10 km/h or more and uses information from sensors to detect an imminent collision and, if the driver fails to take appropriate avoidance action, automatically applies sufficient braking to avoid the collision or at least reduce the collision speed. Different sub-categories of AEB are currently considered:

AEB bus front to vehicle rear – An AEB system that detects and responds to imminent collisions where the front of the equipped vehicle would collide with the rear of another vehicle directly ahead of it.

AEB Pedestrian – An AEB system that detects and responds to imminent collisions with pedestrians.

AEB Cyclist – An AEB system that detects and responds to imminent collisions with pedal cycles and their riders.

- **Approval Authority:** The Approval Authority is the body within TfL that certifies that a bus is approved for use in the TfL fleet and assigns its score under the bus safety standard for use in procurement processes.
- **FCW: Forward Collision Warning** – An audiovisual warning that is provided automatically by the vehicle in response to the detection of a likely collision to alert the driver.
- **OEM: Original Equipment Manufacturer** - The business responsible for the manufacture of the bus being assessed.
- **PBC: Peak Braking Coefficient** – The measure of tyre to road surface friction based on the maximum deceleration of a rolling tyre, measured using the American Society for Testing and Materials (ASTM) E1136-10 (2010) standard reference test tyre, in accordance with ASTM Method E 1337-90 (reapproved 1996), at a speed of 64.4km/h, without water delivery.
- **Test Path:** For the bus stop test, the test path is defined by the co-ordinates specified in Appendix A. For all other tests, the test path is a virtual straight-line path equivalent to the centreline of the lane in which the collision occurs.
- **Test Scenario:** An arrangement and movement of vehicles and test equipment that is intended to represent a particular collision type. A range of different test scenarios are referred to in this protocol:

Bus-to-Car Rear Stationary (BCRS) – A collision in which a bus travels forwards towards another stationary vehicle and the frontal structure of the bus strikes the rear structure of the other vehicle.

Bus-to-Pedestrian Farside Adult 50% (BPFA-50) – A test scenario representing a collision in which a bus travels forwards towards an adult pedestrian crossing its path running from the farside and the frontal structure of the bus strikes the pedestrian at 50% of the width of the bus when no braking action is applied.

Bus-to-Pedestrian Nearside Adult 25% (BPNA-25) – A test scenario representing a collision in which a bus travels forwards towards an adult



pedestrian crossing its path walking from the nearside and the frontal structure of the bus strikes the pedestrian when it has crossed 25% of the width of the bus when no braking action is applied.

Bus-to-Pedestrian Nearside Adult 75% (BPNA-75) – A test scenario representing a collision in which a bus travels forwards towards an adult pedestrian crossing its path walking from the nearside and the frontal structure of the bus strikes the pedestrian when it has crossed 75% of the width of the bus when no braking action is applied.

Bus-to-Pedestrian Nearside Child 50% (BPNC-50) – A test scenario representing a collision in which a bus travels forwards towards a child pedestrian crossing its path running from behind and obstruction from the nearside and the frontal structure of the bus strikes the pedestrian when it has crossed 50% of the width of the bus when no braking action is applied.

Bus-to-Bicyclist Longitudinal Adult 25% (BBLA-25) – A collision in which a bus travels forwards towards a bicyclist cycling in the same direction in front of the bus where the bus would strike the cyclist at 25% of the width of the bus assuming that no braking or steering is applied in response to any FCW issued.

Bus-to-Bicyclist Longitudinal Adult 50% (BBLA-50) – A collision in which a bus travels forwards towards a bicyclist cycling in the same direction in front of the bus where the bus would strike the cyclist at 50% of the width of the bus when no braking or steering action is applied.

Aborted Crossing Test - A scenario in which a bus travels forwards towards a child pedestrian on a crossing trajectory, walking from the nearside and, prior to the child pedestrian actually entering the path of the bus, the child pedestrian stops.

Bus Stop Test – A scenario in which a bus follows a defined curved path first left then right such that the nearside front corner of the bus passes a stationary adult pedestrian.

- **Test Service:** The organisation undertaking the testing and certifying the results to the Approval Authority.
- **Test Target (TT):** An item of test equipment accurately representing the characteristics of the relevant road user, as seen by the relevant sensing technologies used by AEB. A range of specific test targets are defined¹:

EBT: Euro NCAP Bicyclist and Bike Target – Means the bicyclist and bike target as specified in ISO 19206: Part 4.

EPTa: Euro NCAP Pedestrian Target – Means the adult pedestrian target with articulating legs as specified in ISO 19206: Part 2.

EPTc: Euro NCAP Child Target – Means the child pedestrian target as specified in ISO 19206: Part 2.

¹ ISO standards for these test targets are under development and once published should replace the references to the equivalent Euro NCAP standards



EVT: Euro NCAP Vehicle Target – Means the rear end car target defined in ISO 19206: Part 1

GVT: Global Vehicle Target – Means the 3-Dcar target defined in ISO 19206: Part 3.

- **Vehicle width:** The widest point of the vehicle ignoring the rear-view mirrors, side marker lamps, tyre pressure indicators, direction indicator lamps, position lamps, flexible mud-guards and the deflected part of the tyre side-walls immediately above the point of contact with the ground.
- **Vehicle Under Test (VUT):** Means the vehicle assessed according to this protocol.

6 Reference system

6.1 Local co-ordinates

A local co-ordinate system (x,y,z) for the VUT shall be defined such that the x-axis points toward the front of the bus, the y-axis towards the left and the z-axis upwards, as shown in Figure 15_1, below.

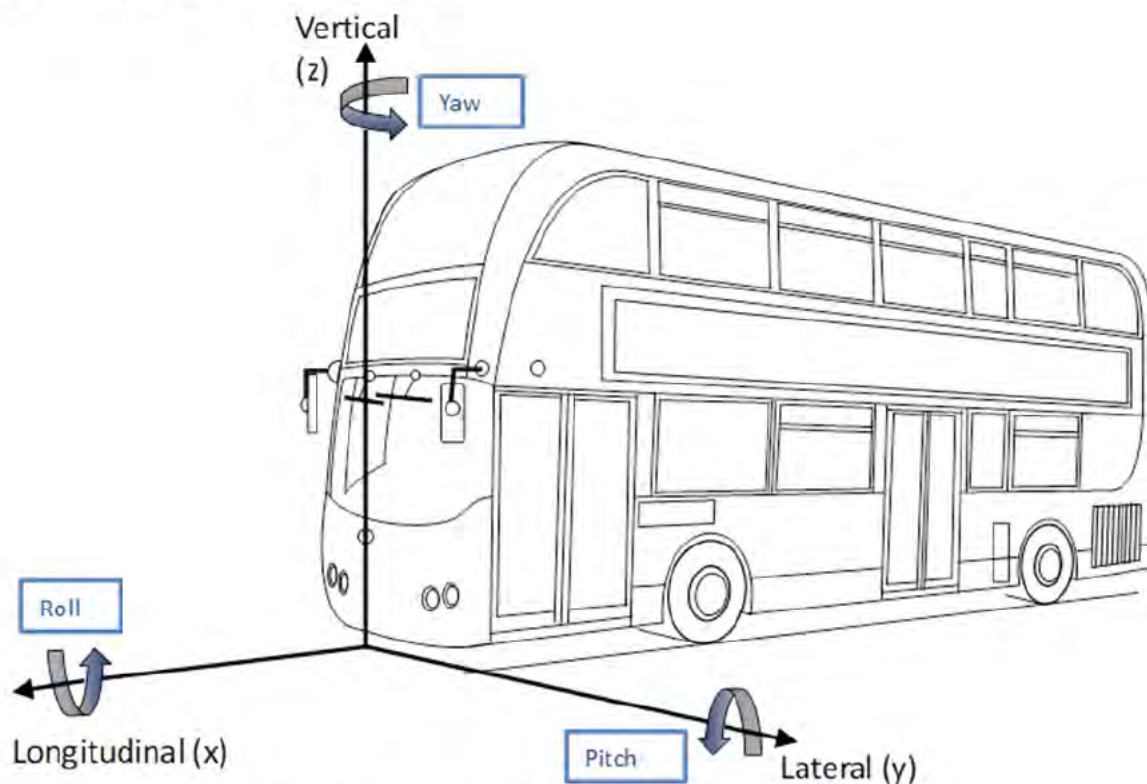

Figure 15_1: Local co-ordinate system and notation

The origin of the co-ordinate system shall lie on the ground plane, on the lateral centre line of the bus at its foremost point (ignoring the rear-view mirrors and windscreen wipers).



6.2 Global co-ordinates

A global co-ordinate system (X, Y, Z) fixed relative to the Earth shall be defined such that the global X-axis is coincident with the local X-axis of the vehicle in its initial starting position. Thus, a VRU travelling perpendicular to the initial direction of the test vehicle would be travelling along the global Y-axis.

7 Measurements and variables

7.1 Variables to be measured

Table 15_1 and Table 15_2 show the variables which must be measured, along with the minimum operating ranges and measurement accuracy required.

Table 15_1: Variables to be measured continuously during each test with minimum operating ranges and measurement accuracy

Variable	Operating range (at least)	Measurement accuracy
Time	24 Hours	GPS Time
Position (global co-ordinates) of the VUT (X_{VUT} , Y_{VUT})	400m in X and 100m in Y	$\pm 0.03\text{m}$
Position (global co-ordinates) of the TT (X_{TT} , Y_{TT})	400m in X and 100m in Y	$\pm 0.05\text{m}$
Speed of the VUT (V_{VUT})	0 km/h to 80 km/h	0.1 km/h
Speed of the TT (V_{TT})	0 km/h to 30 km/h	0.1 km/h
Heading (yaw) angle (Ψ) relative to global X-axis (Ψ_{VUT} , Ψ_{TT})	0° to 360°	0.1°
Yaw velocity of the VUT (Ψ'_{VUT})	$\pm 50^\circ/\text{s}$	$0.1^\circ/\text{s}$
Steering wheel velocity of the VUT (Ω'_{VUT})	$\pm 1000^\circ/\text{s}$	$1.0^\circ/\text{s}$
Pitch angle of the VUT (θ_{VUT})	$\pm 45^\circ$	0.1°
Roll angle of the VUT (ω_{VUT})	$\pm 45^\circ$	0.1°
Acceleration of VUT in local x-axis (A_{VUTx})	$\pm 15 \text{ m/s}^2$	0.1 m/s^2
Acceleration of VUT in local y-axis (A_{VUTy})	$\pm 15 \text{ m/s}^2$	0.1 m/s^2
Acceleration of TT in global y-axis (A_{TTY})	$\pm 15 \text{ m/s}^2$	0.1 m/s^2
FCW Activation ($FCWA$)	True/False	N/A



Table 15_2: Variables to be measured before each test with minimum operating ranges and measurement accuracy

Variable	Operating range (at least)	Measurement accuracy
Ambient Temperature	-5°C to +50°C	± 1°C
Track Temperature	-5°C to +50°C	± 1°C
Wind Speed	0 m/s to 20 m/s	± 0.2m/s
Ambient Illumination	0 lx to 150,000 lx	±10%

7.2 Measuring equipment

Details of the sensors used to measure the required variables shall be recorded in the test report together with the position in which they are installed within the VUT (measured relative to the local co-ordinate system for the test vehicle).

The default equipment to be used shall be a high quality inertial navigation system in combination with differential GPS. Data shall be recorded at a sample rate of 100 Hz. With such equipment, post-sampling digital filtering shall be as follows:

- a) Position and speed require no additional digital filtering after data capture;
- b) Acceleration and yaw rate shall be filtered with a phaseless digital filter complying with the requirements of ISO 15037-2:2002.

Alternatively, any measuring equipment that can be demonstrated to be compliant with the requirements of ISO 15037-2:2002 is permitted.

In addition to the data recording described above, the VUT shall be equipped with one or more video cameras positioned such that for each and every test, the TT can be clearly seen at the moment of impact, at impact points ranging from 1% to 99% of the vehicle width. A means of accurately synchronising the video feed with the data recordings shall be provided. This camera footage is intended for engineering use only in order to provide a visual reference to allow cross-checking of post-processed data. Camera mounting position, lens type etc. are not considered important for this purpose provided impact position or timing of avoidance can clearly be seen in the resulting footage.



7.3 Variables to be derived from the measurements

7.3.1 General

The variables that shall be calculated from the measured data are defined in Table 15_3.

Table 15_3: Variables to be derived from the measured data

Variable	Description	Definition/Derivation Method
AVUT_Long	VUT Longitudinal Acceleration	The component of A_{VUTx} acting in the horizontal plane, or A_{VUTx} corrected for pitch angle
APEAK_VUT_Long	Peak Longitudinal Acceleration of VUT	The largest value of A_{VUT_Long} that occurs between the time T_{AEB} and the end of test
AVUT_Lat	VUT Lateral Acceleration	The component of A_{VUTy} acting in the horizontal plane, or A_{VUTy} corrected for roll angle
T_0	The start of the test	Derived by recording the time T when the measured TTC first drops below 4s
TTC	Time To Collision	For every data point a calculation of the time taken for the VUT to reach the point of impact with the TT based on the current position of each and an assumption that the velocity of each (in the direction of travel of the VUT) remains constant
T_{AEB}	The time at which AEB activates	Find the first data point when the filtered A_{VUT_Long} is -1m/s^2 or larger, then move backwards in time to find the data point where the acceleration first crossed -0.3m/s^2 . The time at this point is T_{AEB} .
T_{FCW}	The time at which FCW activates	The time recorded at the first data point where $FCW_A = \text{True}$, based on recognition of the audible component of the warning. The means of recognition may need to vary depending on the exact system but may, for example, be achieved using a microphone in close proximity to the warning speaker where the signal is filtered with a pass band of 50Hz either side of the measured tone and dB(A) fast weighting applied, and noting the time when the weighted signal exceeds 50dB(A)
T_{Impact}	The time at which the VUT collides with the TT	See section 5.3.2.



Variable	Description	Definition/Derivation Method
V_{Test_VUT}	Nominal initial velocity of VUT before braking applied	Defined by specific test condition
$V_{Test_VUT_Act}$	Actual initial velocity of VUT before braking applied	Average of V_{VUT} over the 1 second immediately before T_{AEB}
V_{Rel_Test}	The initial speed of the VUT relative to the initial speed of the TT	Subtract the component of V_{Test_TT} acting in the same direction as the V_{VUT} from. $V_{Test_VUT_Act}$
V_{Test_TT}	The initial speed of the TT	Average of V_{TT} between T_0 and T_{AEB}
V_{Impact_VUT}	VUT velocity at the moment that it collides with the Test Target	See section 5.3.2
V_{Impact_TT}	Test Target velocity at the moment that it collides with the VUT	See section 5.3.2
V_{AEB_Red}	The reduction in VUT velocity achieved before impact as a consequence of AEB action	$(V_{Test_VUT} - V_{Rel_Impact})/V_{Test_VUT}$
V_{Rel_Impact}	The relative impact speed between VUT and TT at the moment of impact	Subtract the component of V_{Impact_TT} acting in the same direction as the V_{VUT} from. V_{Impact_VUT}
Y_{Impact_Nom}	Nominal Impact Position on VUT if no braking occurred and V_{TT} remains constant	Locate T_{AEB} in the data file. Move forward in time in the data by the number of data points equivalent to the TTC recorded at the data point corresponding to T_{AEB} . Y_{Impact_Nom} is equal to the value Y_{TT} at this data point (actual for true positive tests, calculated for aborted crossing test).
Y_{Impact_Act}	Actual Impact Position on VUT	If no impact occurred this shall be recorded as not applicable. Where impact was deemed to occur, $Y_{Impact_Act} = Y_{TT}$ when that impact first occurred.
Y_{VUT_Error}	Lateral path error of	Distance in y-axis between the centreline of

Variable	Description	Definition/Derivation Method
	the VUT	the vehicle at the foremost point of the VUT at the point of impact, and the same point if the VUT had followed its intended straight path.

7.3.2 Determination of impact

Determining whether impact has occurred and, if so, at what time and speed, is undertaken using a virtual method. A virtual profile is defined around the VUT and each TT and related to the point on the VUT/TT that relates to the recording of its position (X_{VUT} , Y_{VUT} , X_{TT} , Y_{TT}). The first data point at which the recorded positions are such that the virtual profile of VUT and TT intersect is defined as the moment of collision. T_{Impact} , V_{Impact_VUT} , and V_{Impact_TT} are defined as the relevant time and speeds recorded at the moment of collision. This is illustrated in Figure 15_2.:

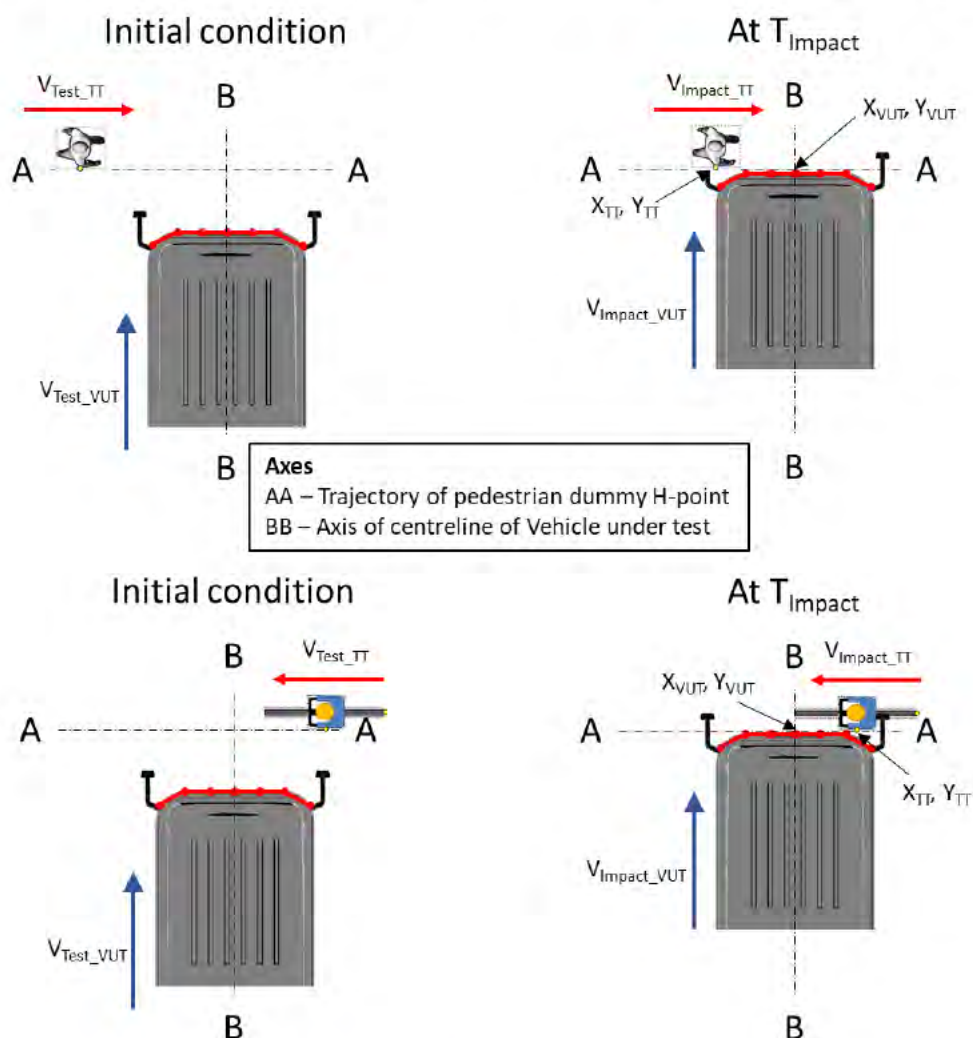

Figure 15_2: Illustration of the definition of the moment of impact (Pedestrian (top), Cyclist (bottom))

For the VUT, the virtual profile is defined around the front end of the vehicle by straight lines connecting seven points that are equally distributed over the vehicle width minus 50 mm on each side as shown in Figure 15_3. The x,y coordinates of each point shall be provided by the OEM and checked by the organisation undertaking the tests.

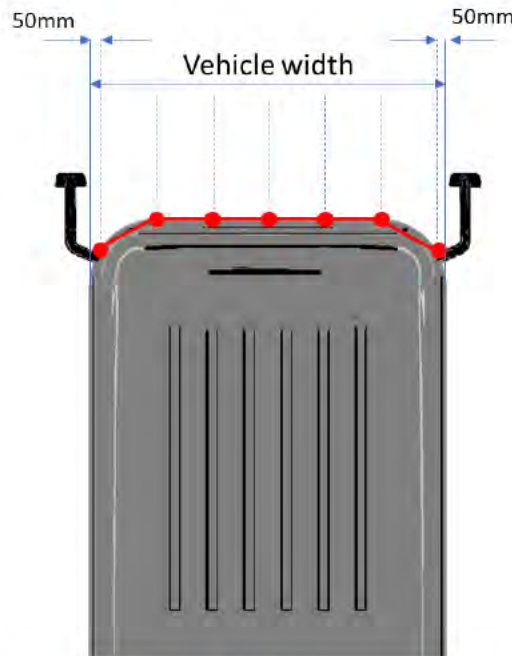

Figure 15_3: Virtual profile for determining impact for VUT

For the vehicle targets, EVT and GVT, they are considered essentially rectangular and should have a local X-axis completely aligned (within defined tolerances) with the local X-axis of the VUT². Thus, a single X position is defined representing the rear of the vehicle target. Impact occurs when the foremost point of the virtual profile for VUT crosses the X position at the rear of the vehicle target.

For the pedestrian targets (EPT) a virtual box is defined around the target with dimensions as shown in Figure 15_4. For crossing scenarios, the reference point is the X,Y position of the hip and for longitudinal scenarios, it is a virtual point positioned where the centreline of the target meets the rear of the virtual box.



Figure 15_4: Virtual box around EPT

² Note that the GVT does in fact have a slightly curved rear profile but this does not affect the moment of impact determination in full overlap conditions as prescribed by this protocol, only in partial overlap conditions.

For the cyclist targets (EBT), the dimensions of the virtual box are shown in Figure 15_5. For crossing scenarios, the reference point of the EBT is the centre of the bottom bracket (crank shaft, indicated by a dashed line in Figure 15_5) and for the longitudinal scenario the most rearward point on the rear wheel is used.

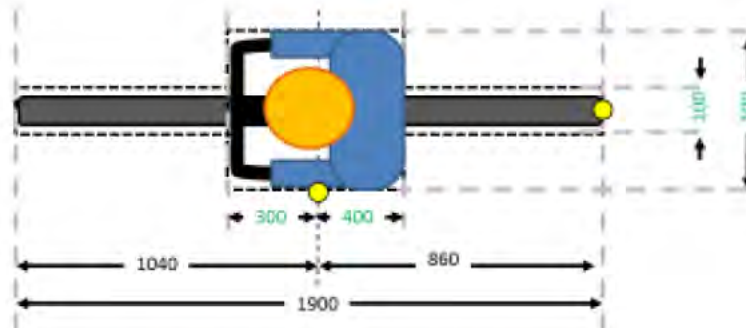

Figure 15_5: Virtual box around EBT

8 Test conditions

8.1 Test track

Tests shall be conducted on a dry (no visible moisture on the surface), uniform, solid-paved surface with a consistent slope between level and 1%.

The test surface shall have a minimal peak braking coefficient (PBC) of 0.9 in the region where data is recorded.

The test zone surface shall be paved and shall not contain any irregularities (e.g. large dips or cracks, manhole covers or reflective studs) that may give rise to abnormal sensor measurements.

The test zone shall extend to a lateral distance of 3.0m either side of the test path and to a longitudinal distance of 30m ahead of the VUT when the test ends.

The presence of lane markings is allowed. However, testing shall only be conducted in an area where typical road markings depicting a driving lane are not parallel to the test path within 3.0m either side. Lines or markings may cross the test path, but shall not be present in the area where AEB activation and/or braking after FCW is expected.

8.2 Weather and lighting conditions

Tests shall be conducted in dry conditions with ambient temperature above 5°C and below 40°C.

No precipitation shall be falling and horizontal visibility at ground level shall be greater than 1km.

Wind speeds shall be below 10m/s to minimise EPT, EBT and VUT disturbance. The Test Service may, at their discretion repeat tests if unexpected results are observed at a time when wind speed exceeds 5 m/s.



For daytime testing, natural ambient illumination shall be homogenous in the test area and in excess of 2000 lux for daylight testing with no strong shadows cast across the test area other than those caused by the VUT, EPT or EBT. Testing shall not be performed driving towards, or away from the sun when there is direct sunlight.

Testing at low ambient lighting conditions are defined herein as night-time tests. The conditions for those tests shall be as defined by ANNEX B of the Euro NCAP AEB VRU test protocol (2018).

8.2.1 Surroundings

Tests shall be conducted in clear surroundings such that there are no other vehicles, highway infrastructure (except lighting columns during the low ambient lighting condition tests), obstructions, other objects or persons protruding above the test surface that may give rise to abnormal sensor measurements. The clear zone shall be defined for the VUT test path as per Figure 15_6, with a longitudinal distance of 30m ahead of the VUT when the test ends and The clear zone for the EPT and EBT shall extend on all sides by 1.0m

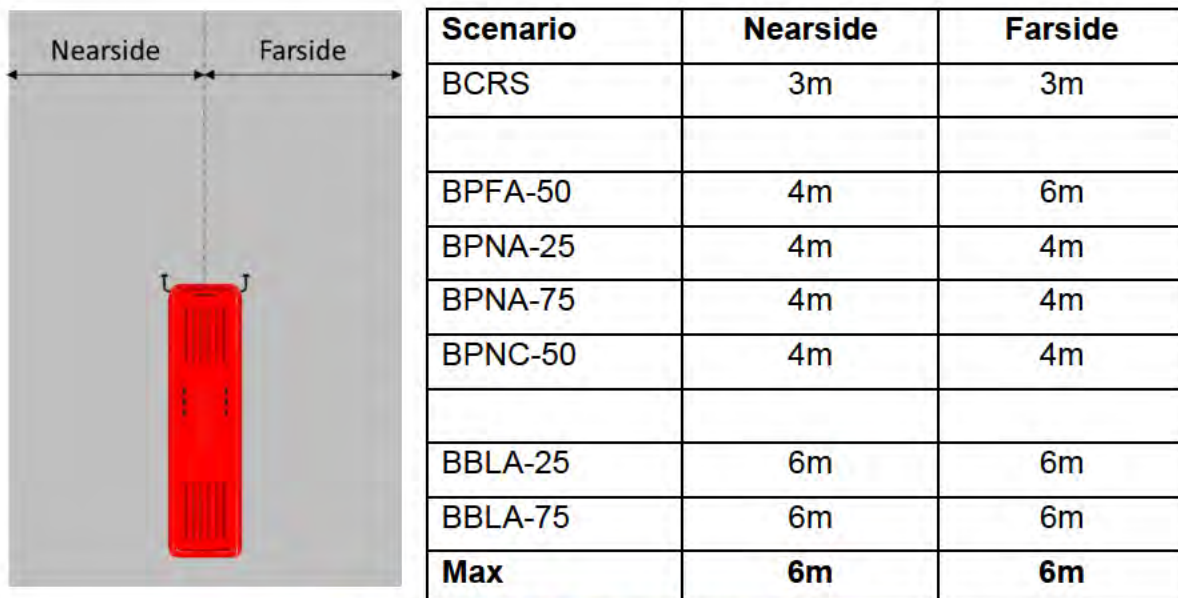

Figure 15_6: Free surroundings

Test areas where the VUT would need to pass under overhead signs, bridges, gantries or other significant structures are not permitted.

The general view ahead and to either side of the test area shall comprise of a wholly plain man made or natural environment (e.g. further test surface, plain coloured fencing or hoardings, natural vegetation or sky etc.) and shall not comprise any highly reflective surfaces or contain any vehicle-like silhouettes that may give rise to abnormal sensor measurements.



9 Vehicle preparation

9.1 Deployable protection systems

If the vehicle is equipped with any external deployable safety systems (for example, pedestrian airbag), then this should be disabled before testing commences.

9.2 Tyres

Perform the testing with new (>90% original tread depth across the tread width) original fitment tyres of the make, model, size, speed and load rating as specified by the OEM.

Replacement tyres are permitted and may be supplied by the manufacturer or acquired at an official dealer representing the manufacturer. Replacement tyres must be of identical make, model, size, speed and load rating to the original fitment.

Tyres shall be inflated to the manufacturers recommended pressure. They shall be set when the tyres are cold and re-checked at the start of every test day.

9.3 Wheel alignment measurement

The vehicle shall be subject to a vehicle (in-line) geometry check to record the wheel alignment in test condition.

Wheel alignment measurement shall be done with the vehicle at kerb weight.

9.4 Vehicle mass

The AEB shall be operative at all states of load.

VUT shall be tested and assessed unladen with only the driver and test equipment on board.

Each axle of the vehicle shall be weighed in the condition as tested and the measurements recorded in the test report.

At the discretion of the Approval Authority, additional tests may be undertaken in full or partial load conditions to assess the extent of any performance degradation compared to unladen.

9.5 AEB/FCW system check

As part of vehicle preparation, it is recommended to perform a maximum of 10 runs at the lowest test speed at which the system is expected to work for each scenario to ensure proper functioning of the system before formal testing begins. This check may be performed using static targets without instrumentation or driving control or within a fully equipped test scenario, as deemed appropriate by the Test Service and agreed with the OEM.



9.6 Measuring front end geometry

The X-Y co-ordinates for the virtual front-end vehicle contour given by the OEM shall be verified.

When the co-ordinates specified are within 10mm of those measured by the Test Service, the co-ordinates as provided by the OEM will be used.

When the co-ordinates measured by the Test Service are not within 10mm of those supplied, or where the OEM has not provided the required data, the co-ordinates as measured by the Test Service shall be used.

10 Test procedure

10.1 VUT pre-test conditioning

10.1.1 Sensor calibration

If requested by the OEM, the Test Service shall drive a maximum of 100km on a mixture of urban roads with other traffic and roadside furniture to 'calibrate' the sensor system. Harsh acceleration and braking shall be avoided.

10.1.2 Brake conditioning

It shall be ensured that the brake assemblies are suitably run-in (also referred to as bedded in) and brake surfaces are neither brand new nor corroded.

10.1.3 Tyre conditioning

Tyres shall have been used in normal driving for at least a distance of 150km.

At the start of each sequence of testing, tyres shall be warmed up by driving for 1 km repeatedly steering left and right with a lateral acceleration of approximately 3 m/s².

10.1.4 Alignment checks

Before testing is undertaken and if any unexpected performance is observed during the tests, the Test Service shall consider checking the test equipment is correctly reproducing the intended test scenario.

For BCRS tests, this shall involve a static alignment test where the VUT is positioned on the test path while just touching the rear of the TT. The vehicles shall be manually measured to ensure that the centreline of the VUT and TT are aligned. The co-ordinates that the inertial measuring system report for the VUT at that time shall be recorded and retained for reference during analysis.

For VRU tests involving crossing scenarios static and dynamic tests shall be considered.

For static tests, position the VUT on the test path with the foremost point of the vehicle positioned on the X-axis at the point where impact with the TT would be expected. Move the TT to the Y-position expected to correspond to the intended impact point (25%, 50%, 75%). Measure the distance from the TT reference point to



the edge of the bus in the Y-axis and calculate the actual impact point (%). Check that error complies with requirement.

For dynamic tests, run the desired test scenario without a TT in position such that AEB does not activate. Analyse the data to identify Y_{Impact_Act} and check that it complies with the requirements for that scenario.

10.2 Protection of Equipment

The near vertical front of buses can make it more likely that test targets, particularly pedestrians, may be damaged during test runs where the AEB does not fully avoid impact. The test service may take all reasonable steps to protect the dummy from excessive damage in tests where impact cannot be avoided, provided that it does not influence the test result. This includes but is not necessarily limited to:

- Not testing at higher speeds when no speed reduction has been achieved at a lower speed, provided there is confidence that the absence of performance was not due to limited horizontal field of view angle of the sensing system.
- Where manufacturers provide expected test results that anticipate dummy impacts at high speeds and the test house verify the accuracy of manufacturers results at the highest speeds, lower speed tests where impacts are still expected can be omitted.
- [The test service may choose to test all configurations where avoidance is expected first and to cease testing once the minimum pass mark has been achieved]
- Braking may automatically be applied via the service brake pedal by the automated test device at the moment of impact. Where a lag exists between pedal application and deceleration, the pedal may be applied in advance of the impact point such that deceleration commences at the impact point.
- Devices that attempt to rapidly physically move the dummy out of the path of the vehicle are only permitted after the point of impact and not before.

10.3 Car tests

10.3.1 Test scenario

The performance of the VUT AEB system in the BCRS scenario is assessed in relation to a stationary target only. FCW is not assessed.

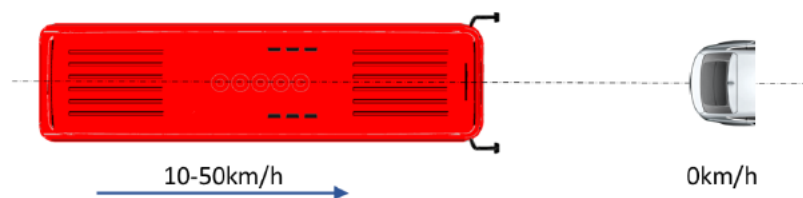

Figure 15_7: BCRs Scenario

The default TT is the EVT. However, the GVT may be used if requested by the OEM.



10.3.2 Sequence and number of test runs

Testing shall be commenced at the lowest test speed ($V_{TEST_VUT} = 10 \text{ km/h}$). Whether to do the next test and, if so, at which test speed depends on the result of the preceding test:

- a) If the result of the test is complete avoidance at that speed, then the next test speed (V_{TEST_VUT}) shall be incremented upwards by 10 km/h;
- b) If the result of the test is contact at a speed at least 5 km/h less than the test speed ($V_{TEST_VUT} - V_{IMPACT_VUT} \geq 5 \text{ km/h}$), and the test speed (V_{TEST_VUT}) was equal to 10 km/h, then the test speed shall be incremented upwards by 5 km/h;
- c) If the result of the test is contact at a speed at least 5 km/h less than the test speed ($V_{TEST_VUT} - V_{IMPACT_VUT} \geq 5 \text{ km/h}$), and the test speed (V_{TEST_VUT}) was greater than 10 km/h, the test speed shall be reduced by 5 km/h and then subsequent tests at increased speeds incremented at 5 km/h; or
- d) If the result of the test was a speed reduction of less than 5 km/h ($V_{TEST_VUT} - V_{IMPACT_VUT} < 5 \text{ km/h}$), or if the OEM states that they expect no performance at the next speed, then testing shall cease.

Tests shall not be undertaken at speeds in excess of 50 km/h. Only one valid test is required at each speed and the result from the first valid test shall be the result officially recorded.

Additional tests may be undertaken in order to investigate unexpected results at the discretion of the OEM, Test Service or Approval Authority. If so, the Test Service shall provide all data from repeat runs to the Approval Authority for their consideration.

10.3.3 Test execution

- a) If requested by the OEM, an initialisation process shall be completed before the first, or every, test run.

The initialisation shall involve driving the vehicle on a circular path of radius $\leq 30 \text{ m}$ for a distance of 190m, half of which involves a left turn and half a right turn. At the request of the OEM this may also involve driving past a small number of parked vehicles. The initialisation process shall be completed before the tyre warm up.

- b) The first test shall be commenced a minimum of 90 seconds and a maximum of 10 minutes after completion of the tyre warmup. Subsequent tests shall be completed within this same time window.

If the time between tests exceeds 10 minutes, then repeat the tyre warmup procedure.

- c) Select the normal Drive mode of the vehicle/gearbox.
- d) Accelerate the VUT to the test speed, position it on the test path and achieve steady state conditions before T_0 ($TTC=4\text{s}$).
- e) If the VUT instigates AEB, then the accelerator pedal shall be released. No other driving controls (e.g. clutch or brake) shall be operated during the test.



- f) The test is considered complete when one of the following has occurred:
- i. $V_{VUT} = 0$ km/h
 - ii. VUT has made contact with the TT.

10.3.4 Validity of tests

Post-processing of data shall be undertaken to demonstrate the validity of tests. Tests are considered valid when all of the following criteria are met at all times between T_0 and T_{AEB} :

- a) $V_{VUT} \geq \text{Test Speed}$ and $V_{VUT} \leq \text{Test Speed} + 1$ km/h
- b) Lateral deviation from VUT Test Path (Y_{VUT_Error}) = 0 ± 0.05 m
- c) VUT Yaw Velocity (Ψ'_{VUT}) = 0 ± 1.0 °/s
- d) Steering wheel velocity (Ω'_{VUT}) = 0 ± 15.0 °/s
- e) Centreline of the Test Target is within ± 0.05 m of the Test path and parallel to the Test path within $\pm 5^\circ$

To consistently meet these tolerances, electro mechanical control systems shall be used to apply the driving controls.

If a test is found to be non-compliant then it shall be repeated until a compliant result is achieved.

10.4 VRU crossing tests

10.4.1 Test scenarios

The performance of the system shall be assessed in the four scenarios BPFA-50, BPNA-25, BPNA-75 and BPNC-50 and these are illustrated in Figure 15_8 to Figure 15_10 . FCW is not assessed.

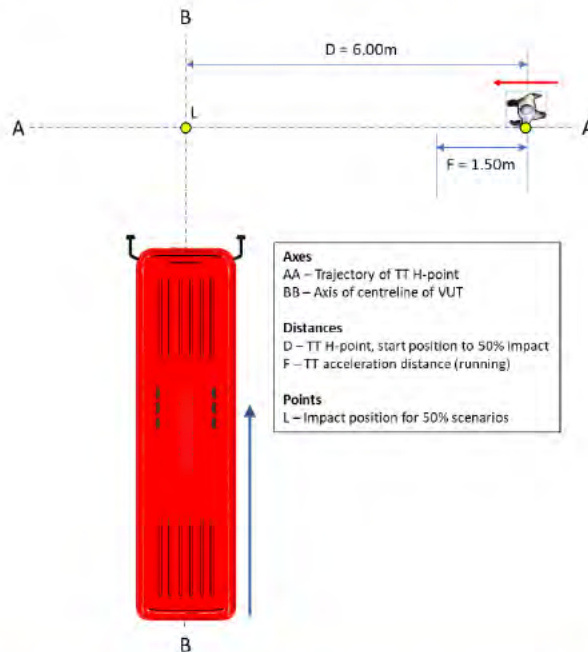

Figure 15_8: BPFA-50 scenario, adult running from the farside of the road

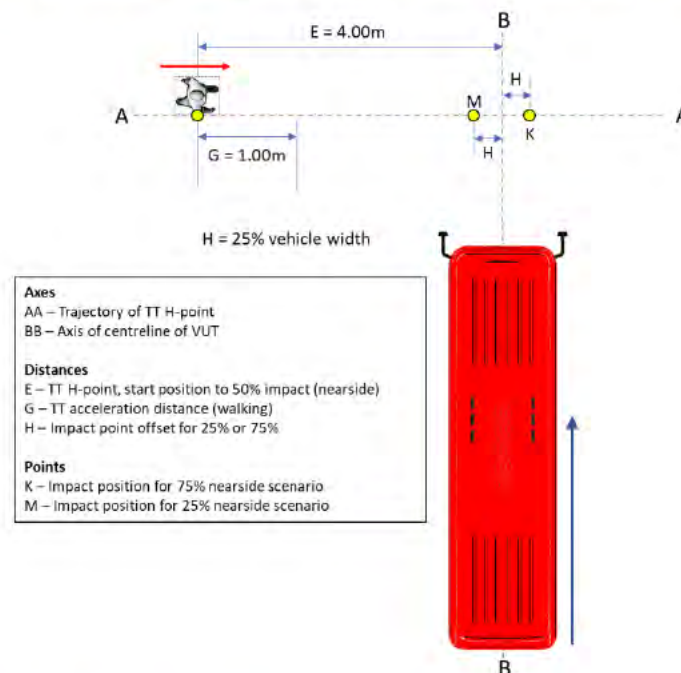

Figure 15_9: BPNA-25 & BPNA-75 scenario, adult walking from the nearside of the road

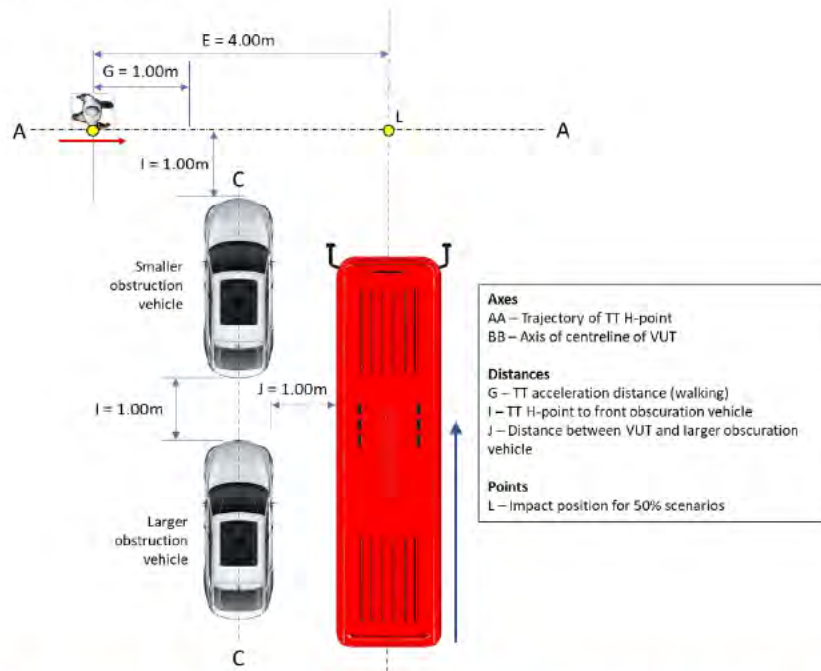

Figure 15_10: BPNC-50 scenario, child running from the nearside from behind obstructing vehicles

Figure 15_10 defines the relative position of the obstructing vehicles. The definition of the size and type of vehicles to be used is that specified in the Euro NCAP AEB VRU systems protocol (2018).

In all scenarios except BPNC-50, the TT to be used is the Euro NCAP Pedestrian Target adult dummy (EPTa). For scenario BPNC-50, the test target shall be the Euro NCAP Pedestrian Target child dummy (EPTc).

The details of the tests are shown in Table 15_4.

Table 15_4: Test variables for the VRU crossing tests

	Test Scenario			
	BPFA-50	BPNA-25	BPNA-75	BPNC-50
VUT speed (V_{TEST_VUT})	20 – 45 km/h			
TT speed (V_{TEST_TT})	8 km/h	5 km/h		
Impact location (VUT)	50%	25%	75%	50%
Lighting conditions	Day	Day & Night		Day

In addition to the tests defined in Table 15_4, the BPNA-75 scenario shall be tested in daylight conditions with:

- a) $V_{TEST_VUT} = 20$ km/h and $V_{TEST_TT} = 3$ km/h; and
- b) $V_{TEST_VUT} = 10$ km/h and $V_{TEST_TT} = 5$ km/h.

10.4.2 Sequence and number of test runs

VUT tests speeds (V_{TEST_VUT}) shall be increased in increments of 5 km/h, until $V_{TEST_VUT} = 40$ km/h.



VUT tests speeds in excess of 40 km/h shall only be tested when:

- a) OEM has provided data indicating an expected significant performance at the next speed increment; and
- b) $V_{TEST_VUT} - V_{IMPACT_VUT} \geq 5$ km/h where $V_{TEST_VUT} = 40$ km/h

The number of test runs to be completed in each test condition and the process of determining the result to be recorded for that condition are the same as those defined in section 10.3.2.

10.4.3 Test execution

The process for executing each test shall be as defined in section 10.3.3. with the following exceptions.

T_0 is defined as being at a TTC of 6 seconds.

The test is considered complete when one of the following has occurred:

- a) $V_{VUT} = 0$ km/h
- b) VUT has made contact with the TT
- c) The TT has crossed the full width of the VUT and moved out of its path without making contact with it

10.4.4 Validity of tests

Post-processing of data shall be undertaken to demonstrate the validity of tests. Tests are considered valid when all of the following criteria are met at all times between T_0 and activation of AEB or the end of test, whichever comes first:

- a) $V_{VUT} \geq$ Test Speed and $V_{VUT} \leq$ Test Speed + 0.5 km/h
- b) Lateral deviation from VUT Test Path (Y_{VUT_Error}) = 0 ± 0.05 m
- c) Lateral deviation from TT path = 0 ± 0.05 m
- d) Lateral Velocity of deviation from the TT path = 0 ± 0.15 m/s
- e) VUT Yaw Velocity (Ψ'_{VUT}) = 0 ± 1.0 °/s
- f) Steering wheel velocity (Ω'_{VUT}) = 0 ± 15.0 °/s

Once it has reached a steady state condition, the speed of the TT shall remain at the defined speed ± 0.2 km/h. The steady state period shall commence no later than the point when the EPT has reached a lateral distance (Global Y-axis) of both:

- a) 3.0m from the VUT centreline, in tests approached from the nearside
- b) 4.5m from the VUT centreline in tests approached from the farside

In addition to this, Point L = Target value $\pm 3\%$ of vehicle width

To consistently meet these tolerances, electro mechanical control systems shall be used to apply the driving controls.

If a test is found to be non-compliant then it shall be repeated until a compliant result is achieved.

10.5 VRU longitudinal tests

Test scenarios

The VUT shall be assessed in two longitudinal scenarios. Both AEB and FCW shall be assessed. The TT shall be the Euro NCAP Bicyclist and bike Target (EBT). The test scenario is outlined in Figure 15_11, below.

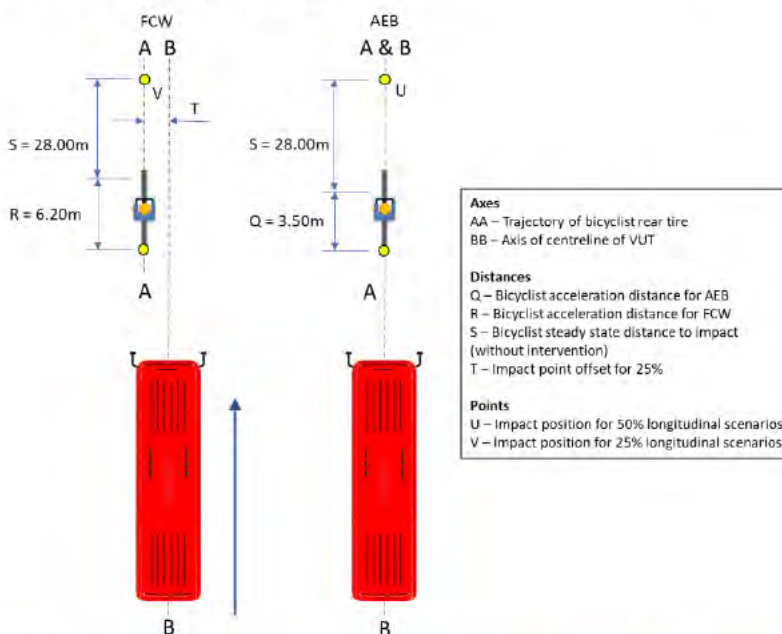

Figure 15_11: Longitudinal bicyclist scenarios; BBLA-25 (left) & BBLA-50 (right)

The tests to be undertaken are as defined in Table 15_5 .

Table 15_5: Test Variables: Longitudinal scenarios

	Test Scenario	
	BBLA-25	BBLA-50
Type of Test	FCW	AEB
VUT speed (V_{TEST_VUT})	50 km/h - 60 km/h	25 km/h – 60 km/h
TT speed (V_{TEST_TT})	20 km/h	15 km/h
Impact location (VUT)	25%	50%
Lighting conditions	Daylight	



10.5.1 Sequence and number of test runs

VUT tests speeds (V_{TEST_VUT}) shall be increased in increments of 5 km/h, until $V_{TEST_VUT} = 40$ km/h.

VUT tests speeds in excess of 40 km/h shall only be tested when:

- a) an OEM has provided data indicating an expected significant performance at the next speed increment; and
- b) $V_{TEST_VUT} - V_{IMPACT_VUT} \geq 5$ km/h where $V_{TEST_VUT} = 40$ km/h.

The number of test runs to be completed in each test condition and the process of determining the result to be recorded for that condition shall be as defined in section 10.3.2.

10.5.2 Test execution

The test execution shall be as specified in section 10.3.3, except that steady state shall be achieved before the time $T_0 - 1$ seconds (that is, 1 second before T_0).

For scenario BBLA-25 only, the test may be aborted if no FCW has been issued when the TTC has reduced to ≤ 1.5 seconds.

10.5.3 Validity of tests

Post-processing of data shall be undertaken to demonstrate the validity of tests. Tests are considered valid when all of the following criteria are met at all times between the time $T_0 - 1$ seconds and T_{AEB} or T_{FCW} :

- a) $V_{VUT} \geq \text{Test Speed}$ and $V_{VUT} \leq \text{Test Speed} + 0.5$ km/h
- b) Lateral deviation from VUT Test Path (Y_{VUT_Error}) = 0 ± 0.05 m
- c) Lateral deviation from TT path = 0 ± 0.15 m
- d) Lateral Velocity of deviation from the TT path = 0 ± 0.15 m/s
- e) VUT Yaw Velocity (Ψ'_{VUT}) = 0 ± 1.0 °/s
- f) Steering wheel velocity (Ω'_{VUT}) = 0 ± 15.0 °/s

Once it has reached a steady state condition, the speed of the TT shall remain at the defined speed ± 0.2 km/h. The steady state period shall commence no later than the point when the TT is positioned 22m forward of the impact point on the VUT.

To consistently meet these tolerances, electro mechanical control systems shall be used to apply the driving controls.

If a test is found to be non-compliant then it shall be repeated until a compliant result is achieved.

10.6 Aborted crossing test

10.6.1 Test scenario

This test scenario has the same geometry as that described for BPNA-25 and illustrated in Figure 15_9 previously. However, the TT shall be the EPTc. As per BPNA-25, the movement of the TT shall be timed such that if the TT continued at its constant steady state speed ($V_{TEST_TT} = 5 \text{ km/h}$) and the VUT maintained constant speed (without braking) and lateral position, an impact would occur 25% across the width of the VUT.

Thus, the TT motion shall be initiated as for BPNA-25. However, instead of the TT continuing at 5 km/h until the end of the test, it shall be stopped with a mean deceleration of $[3] \text{ m/s}^2$ at Point W, where distance N is the distance from the edge of the VUT path, as illustrated in Figure 15_12.

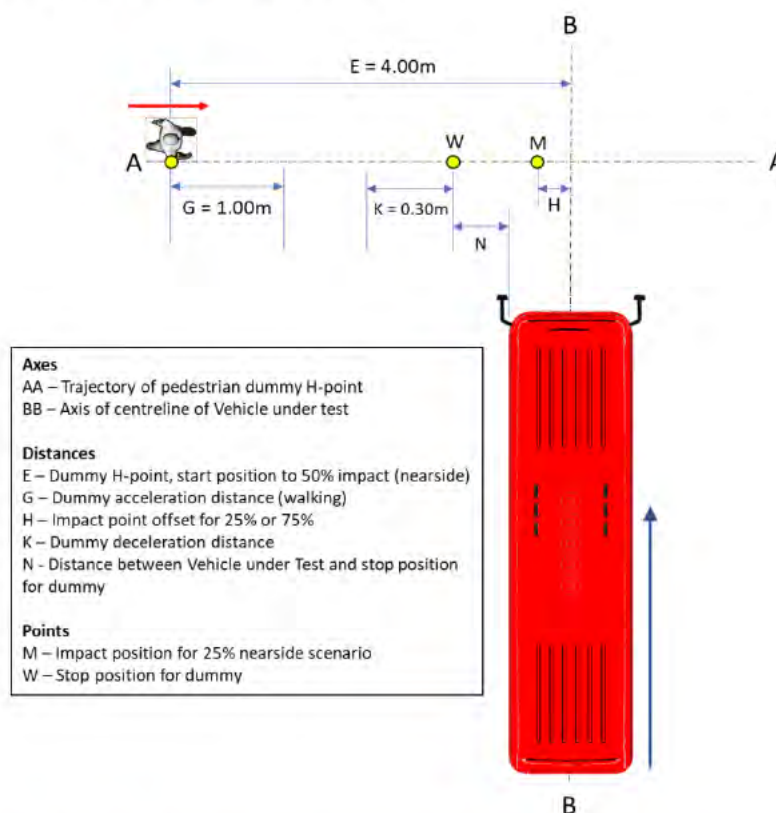

Figure 15_12: TT start and stop positions in aborted crossing test

Tests shall be undertaken at $V_{TEST_VUT} = 30 \text{ km/h}$ for:

- N₁; where N = 0.6 m
- N₂; where N = 0.75 m
- N₃; where N = 0.9 m

10.6.2 Sequence and number of test runs

The first test N₁ shall be undertaken at N = 0.6 m and 3 identical tests shall be completed.



Distance N shall be increased to the next increment if the AEB activates in any of the 3 tests.

If AEB is not activated in any tests then testing can be ceased and the system will be deemed not to have activated in any of the tests at greater values of N.

10.6.3 Test execution

Accelerate the VUT to the test speed (V_{TEST_VUT}), position it on the test path and achieve steady state conditions before T_0 (TTC=4s). For buses with automatic transmission, select Drive (D). For buses with a manual transmission, select the highest gear that results in an engine speed of at least 1,000 RPM at the test speed.

If the VUT instigates AEB, then the throttle pedal shall be released. No other driving controls (e.g. clutch or brake) shall be operated during the test.

The test is considered complete one second after the TT has come to rest ($V_{TT}=0$).

10.6.4 Validity of tests

Post-processing of data shall be undertaken to demonstrate the validity of tests. Tests are considered valid when all of the following criteria are met at all times between T_0 and activation of AEB or the end of test, whichever comes first:

- a) $V_{VUT} \geq \text{Test Speed}$ and $V_{VUT} \leq \text{Test Speed} + 0.5 \text{ km/h}$
- b) Lateral deviation from VUT Test Path = $0 \pm 0.05 \text{ m}$
- c) Lateral deviation from TT path = $0 \pm 0.05 \text{ m}$
- d) Actual measured distance N for tests N_1 , N_2 , and $N_3 = N \pm 0.07 \text{ m}$
- e) Lateral Velocity of deviation from the Test Target path = $0 \pm 0.15 \text{ m/s}$
- f) VUT Yaw Velocity (Ψ'_{VUT}) = $0 \pm 1.0^\circ/\text{s}$
- g) Steering wheel velocity (Ω'_{VUT}) = $0 \pm 15.0^\circ/\text{s}$

Once it has reached a steady state condition, the speed of the TT (V_{TT}) shall remain at the defined speed $\pm 0.2 \text{ km/h}$ until commencement of the deceleration phase.

The nominal impact point (Point M) shall be $25\% \pm 3\%$ of vehicle width.

The deceleration phase shall commence at the time required to achieve the intended point W. The mean deceleration shall be within $\pm 5\%$ of the target value.

To consistently meet these tolerances, electro mechanical control systems shall be used to apply the driving controls.

If a test is found to be non-compliant then the non-compliant tests must be repeated until 3 compliant runs are achieved.

10.7 Bus stop test

10.7.1 VUT path geometry

The bus stop test involves the VUT steering a defined curved path first left then right of 125 m radius such that the nearside front corner of the vehicle describes the path illustrated in Figure 15_13 and defined by the corridor specified in XY co-ordinates in Appendix A.

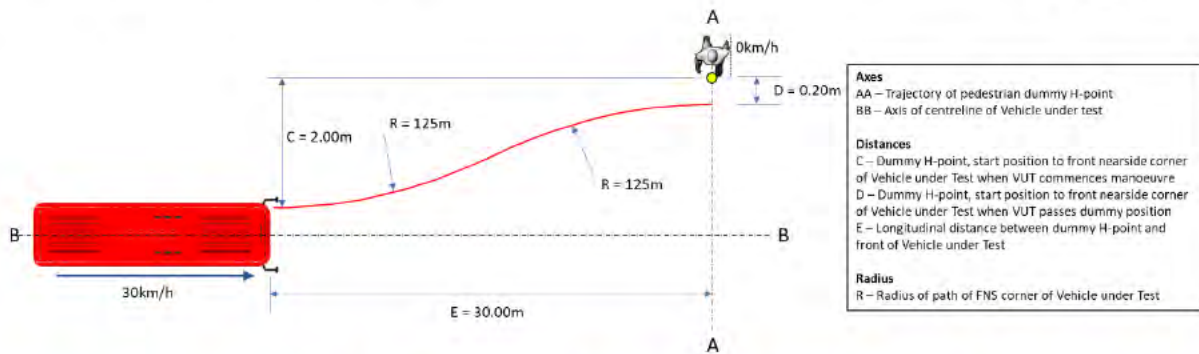

Figure 15_13: VUT Path and pedestrian position in false positive bus stop test

10.7.2 False positive test – TT Stationary

The geometry remains as shown in Figure 15_13. The TT shall always remain stationary and shall be positioned such that the lateral separation (on global Y-axis), between the centre of the TT and the nearside front corner of the VUT, is initially 2 m (Point C).

This distance shall reduce as the VUT approaches the TT until a distance of 0.2 m (Point D) at the moment the front nearside corner of the VUT is at the same position as the TT on the Global X-axis.

V_{VUT} shall be 30 km/h at a distance in the X-axis of 30 m from the line AA. The bus shall be decelerated at a nominally constant rate such that its speed when it reaches line AA is between 0 and 10 km/h, unless AEB is activated.

10.7.3 True positive test – TT non-stationary

As described in Figure 15_14. The TT shall initially be positioned such that the lateral separation (on global Y-axis), between the centre of the TT and the nearside front corner of the VUT, is initially 4.55 m (Point C). The TT shall be accelerated to a speed of $V_{TEST_TT} = 5$ km/h at a time such that it is on a collision course with the front of the VUT where the nominal impact point (Point L) is $50\% \pm 3\%$ of bus width. V_{TEST_VUT} shall be 30 km/h and shall remain constant throughout the test.

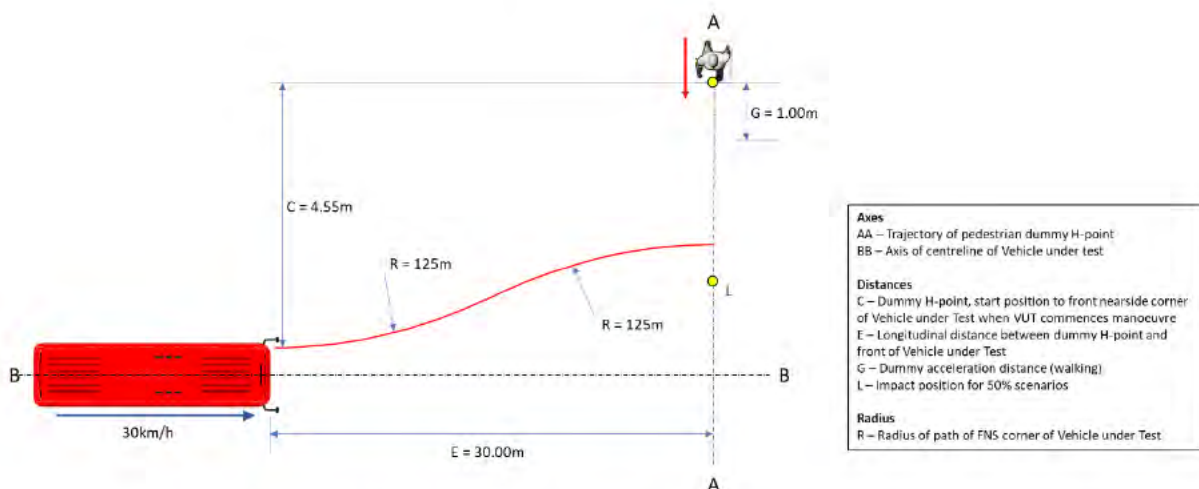

Figure 15_14: VUT path and TT position in true positive bus stop test



10.7.4 Sequence and number of test runs

Each test involves only one test configuration and will be completed only once.

10.7.5 Test execution

Accelerate the VUT to the test speed (V_{TEST_VUT}) in a straight line

Position the front nearside corner at a point that complies with the requirements for the first lateral position defined.

When the front of the VUT reaches a position of 30 m from the TT in the global X-axis, steering is applied such that the front nearside corner stays within the corridor defined by Appendix A.

For buses with automatic transmission, select Drive (D). For buses with a manual transmission, select the highest gear that results in an engine speed of at least 1,000 RPM at the test speed.

If the VUT instigates AEB, then the throttle pedal shall be released. No other driving controls (e.g. clutch or brake) shall be operated during the test.

The test is considered complete when the foremost point of the VUT has passed the position of the TT in the global x-axis, or the VUT has come to rest, whichever occurs first.

10.7.6 Validity of tests

Post-processing of data shall be undertaken to demonstrate the validity of tests.

Tests are considered valid when all of the following criteria are met at all X_{VUT} positions between that representing entry to the corridor defined in Appendix A and activation of AEB or the end of test, whichever comes first:

- a) $V_{VUT} \geq \text{Test Speed}$ and $V_{VUT} \leq \text{Test Speed} + 0.5 \text{ km/h}$
- b) Front nearside corner remains in defined corridor

To consistently meet these tolerances, electro mechanical control systems shall be used to apply the driving controls.

If a test is found to be non-compliant then the non-compliant test shall be repeated.

10.8 Validation of OEM supplied test data

The procedures as outlined above are intended to be applicable as an independent assessment of a bus equipped with AEB capable of standing alone. Where an OEM supplies a Test Service with a prediction of performance in each test condition in terms of both an expected impact speed (0 km/h if it is expected that the system will avoid impact) and, where applicable, the peak deceleration applied to achieve that result, a reduced burden procedure can be undertaken. The Test Service will randomly select a sample of test conditions in which to verify the OEM's result, ensuring a broad cross section of variables are covered which must include (a to d):

- a) For car scenarios, a minimum 3 of 5 test conditions
- b) For crossing scenarios, a minimum 16 of 32 test conditions
- c) For longitudinal scenarios, a minimum 6 of 11 test conditions



d) Aborted crossing and bus stop tests shall always be completed in full.

11 Assessment of results

11.1 Assessment criteria

The true positive performance of AEB shall be assessed using the criteria (V_{AEB_Red}). This is defined as the difference between the test speed and the impact speed, expressed as a percentage of the test speed, where the impact speed is considered to be 0km/h when the impact is avoided.

For the longitudinal cyclist tests the test and impact speeds are defined as the relative speeds of the VUT and the TT. An example of this is shown in Table 15_6.

Table 15_6: Example V_{AEB_Red} for longitudinal cyclist tests

Condition	VUT	TT	Relative
Test Speed (km/h)	50	15	35
Impact Speed (km/h)	30	15	15
V_{AEB_Red} (km/h)			-20
V_{AEB_Red} (%)			57%

FCW shall be assessed on a binary basis, based upon the TTC at the moment the warning is issued (TFCW). When $TFCW \geq 1.7$ seconds then the score shall be 100%. Where $TFCW < 1.7$ seconds, then the score shall be 0%.

11.2 Pre-conditions

The score awarded for AEB will be zero unless the following pre-conditions are met:

- In test BPNA-75 with $V_{TEST_TT} = 3$ km/h and $V_{TEST_VUT} = 20$ km/h then V_{AEB_Red} shall exceed 25% in both day & night conditions
- In test BPNA-75 with $V_{TEST_TT} = 5$ km/h and $V_{TEST_VUT} = 10$ km/h then V_{AEB_Red} shall exceed 25% in both day & night conditions
- The AEB system shall default ON at the start of every journey. It shall not be possible for the driver to easily switch off the system. It shall be possible for technicians to enable a service mode that deactivates it for maintenance and test purposes (for example when placed on a rolling road/brake rollers).
- AEB must not activate in the false positive bus stop test.
- V_{AEB_Red} shall be no less than 1 km/h in the true positive bus stop test.

11.3 Test scenario and crash type scores

Each individual test scenario comprises several individual tests at different initial test speeds. Weightings shall be applied to each individual test within each test scenario and crash type. The speed weightings are defined in the following sections.



11.3.1 Car tests

For scenario BCRS, the score for the test scenario shall be calculated from each individual test run as per the example given in Table 15_7.

Table 15_7: Scoring and weighting applicable to scenario BCRS

Test Speed (km/h)	A	B	C = A*B
	V _{AEB_Red}	Speed Weighting	Weighted score
10	100.0%	5.0%	5.0%
15	100.0%	5.0%	5.0%
20	100.0%	20.0%	20.0%
25	100.0%	15.0%	15.0%
30	100.0%	15.0%	15.0%
35	100.0%	20.0%	20.0%
40	60.0%	10.0%	6.0%
45	20.0%	5.0%	1.0%
50	0.0%	5.0%	0.0%
Total (Scenario Score)			87.0%

The total of the weighted scores for each test speed shall become the scenario score. The car tests only use one test scenario and therefore the scenario score is also the crash type score.

11.3.2 VRU crossing tests

For the VRU crossing tests the score shall be calculated for each individual test run as per the example given in Table 15_8.

Table 15_8: Scoring and weighting applicable to each VRU crossing scenario

Test Speed (km/h)	A	B	C = A*B
	V _{AEB_Red}	Speed Weighting	Weighted score
20	100.0%	20.0%	20.0%
25	100.0%	20.0%	20.0%
30	53.0%	20.0%	10.6%
35	40.0%	20.0%	8.0%
40	20.0%	10.0%	2.0%
45	0.0%	10.0%	0.0%
Total (Scenario Score)			60.6%

The total of the weighted scores for each test speed shall become the scenario score. The process shall be repeated for each of the VRU crossing scenarios.

Each of the different VRU scenarios shall also be weighted according to casualty prevention potential to produce a crash type score for all VRU crossing scenarios. Table 15_9 provides an example of the scenario weighting and the calculation.



Table 15_9: Scoring and weighting to combine scenario scores to crash type score

Scenario	A	B	C = A*B
	Scenario Score	Scenario Weighting	Weighted score
BPFA-50 (Day)	60.6%	15.0%	9.1%
BPNA-25 (Day)	75.4%	26.0%	19.6%
BPNA-25 (Night)	60.7%	22.0%	13.4%
BPNA-75 (Day)	91.0%	18.0%	16.4%
BPNA-75 (Night)	80.0%	15.0%	12.0%
BPNC-50 (Day)	70.0%	4.0%	2.8%
Total (Crash Type Score)			73.2%

11.3.3 VRU longitudinal tests

The VRU longitudinal tests assess both AEB and FCW. The principles for AEB are identical to the crossing scenarios. Forward collision warning shall be assessed according to TFCW. The scores shall be calculated for each individual test run as per the example given in Table 15_10

Table 15_10: Scoring and weighting for VRU longitudinal tests

Test Speed	BBLA-50 (AEB)			BBLA25-(FCW)		
	A	B	C = A*B	D	E	F=D if E≥1.7
	V _{AEB_Red}	Speed Weighting	Weighted score	Speed Weighting	T _{FCW}	Weighted score
25	100.0%	20.0%	20.0%			
30	100.0%	20.0%	20.0%			
35	80.0%	20.0%	16.0%			
40	40.0%	15.0%	6.0%			
45	0.0%	10.0%	0.0%			
50	0.0%	5.0%	0.0%	40.0%	1.8	40.0%
55	0.0%	5.0%	0.0%	30.0%	1.6	0.0%
60	0.0%	5.0%	0.0%	30.0%	1.5	0.0%
Total (Scenario score)			62.0%	Total (Scenario score)		40.0%
Scenario weighting			75.0%			25.0%
Total (Crash type score)						71.5%

The total of the weighted scores for each test speed shall become the scenario score. Each scenario is weighted to then produce a combined score for the whole crash type.



11.3.4 False positive aborted crossing scenario

The results of the aborted crossing scenario shall be interpreted in terms of the peak acceleration (A_{PEAK_VUT_Long}) measured during any activation. Where the system does not activate A_{PEAK_VUT_Long} shall be deemed to be zero. Scores shall be awarded for each individual test configuration on the following basis:

a) For Test N₁

- i. $A_{PEAK_VUT_Long} \leq -5 \text{ m/s}^2$: 0%
- ii. $A_{PEAK_VUT_Long} > -5 \text{ m/s}^2 \text{ AND } \leq 0 \text{ m/s}^2$: 100%

b) For tests N₂ and N₃

- i. $A_{PEAK_VUT_Long} \leq -5 \text{ m/s}^2$: 0%
- ii. $A_{PEAK_VUT_Long} > -5 \text{ m/s}^2 \text{ AND } \leq -1.5 \text{ m/s}^2$: 50%
- iii. $A_{PEAK_VUT_Long} = -1.5 \text{ m/s}^2 \text{ AND } \leq 0 \text{ m/s}^2$: 100%

The Scenario Score is the mean of each of the 9 test results, as per the example given in Table 15_11.

Table 15_11: Example scoring for false positive aborted crossing tests

TT distance to VUT	Test 1	Test 2	Test 3	Total
N ₁	0%	0%	100%	33.3%
N ₂	50%	100%	50%	66.7%
N ₃	100%	100%	100%	100%
Scenario Score				66.7%



11.4 Overall score

The scores by crash type shall be converted to an overall score for AEB according to weightings based on London bus collision data. A worked example is shown in Table 15_12.

Table 15_12: Scoring & Weighting to produce overall AEB result

Crash Type	A	B	C= A*B	D	E = (ΣC)*D
	Crash type score	Crash type weighting	Weighted score	Performance type weighting	Weighted performance score
True Positive: Car	87.0%	10.0%	8.7%	90%	67.1%
True Positive: VRU crossing	73.2%	85.0%	62.2%		
True Positive: VRU longitudinal	71.5%	5.0%	3.6%		
False positive: aborted crossing	66.7%	100.0%	66.7%	10%	6.7%
Total (Overall AEB Score)					73.8%

12 Test report

The Test Service shall provide a comprehensive test report that will be made available to the Approval Authority. The test report shall consist of three distinct sections:

- a) Performance data
- b) Confirmation of protocol compliance
- c) Reference information

The minimum performance data required is:

- a) The value V_{Impact} and $A_{PEAK_VUT_Long}$ for each and every individual test run, with the number of tests reported based on the rules in, for example, section 10.3.2
- b) For BBLA-25 the performance output is the TTC at T_{FCW} .

To confirm protocol compliance, the Test Service shall:

- a) Make available the video recordings as specified in section 7.2
- b) Include in the report processed data (e.g. graphs, tables etc.) that show that each test was compliant with its respective section on validity of tests
- c) Provide data on environmental validity criteria, including temperature, weather and lighting measurements, demonstrating compliance with respective limit values



The reference information required includes as a minimum:

- a) Vehicle make
- b) Vehicle model
- c) Vehicle model variant
- d) AEB hardware version (e.g. sensor types, ECU references)
- e) AEB software version
- f) Tyre make/model/size/pressure
- g) Test weight
- h) Make, model, serial number of key control and measurement equipment
- i) Details of the Test Service
- j) Test date(s)



Appendix A - Co-ordinate corridor defining the path to be followed by the front nearside corner of the VUT

The co-ordinates defined below are based on the global co-ordinate system as defined in section 6.1, for use in section 8.6.1, assuming the vehicle width is 2.5m. For different vehicle widths all target Y values shall be adjusted by half the difference in width. However, the important element is not the initial offset in Y but the difference in Y between the TT and the VUT initial position and the difference between the VUT Y-position at any given X and its initial Y-Position at X=0.

X	Target Y	Y Position	Corridor which NSF of VUT must lie within
0.00	1.25	1.20	1.30
1.00	1.25	1.20	1.30
2.00	1.27	1.22	1.32
3.00	1.29	1.24	1.34
4.00	1.31	1.26	1.36
5.00	1.35	1.30	1.40
6.00	1.39	1.34	1.44
7.00	1.45	1.40	1.50
8.00	1.51	1.46	1.56
9.00	1.57	1.52	1.62
10.00	1.65	1.60	1.70
11.00	1.73	1.68	1.78
12.00	1.83	1.78	1.88
13.00	1.93	1.88	1.98
14.00	2.04	1.99	2.09
15.00	2.15	2.10	2.20
16.00	2.27	2.22	2.32
17.00	2.38	2.33	2.43
18.00	2.48	2.43	2.53
19.00	2.57	2.52	2.62
20.00	2.65	2.60	2.70
21.00	2.73	2.68	2.78
22.00	2.80	2.75	2.85
23.00	2.86	2.81	2.91
24.00	2.91	2.86	2.96
25.00	2.95	2.90	3.00
26.00	2.99	2.94	3.04
27.00	3.01	2.96	3.06
28.00	3.03	2.98	3.08
29.00	3.04	2.99	3.09
30.00	3.05	3.00	3.10



Attachment 16: Advanced Emergency Braking (AEB) Guidance Notes

1 Introduction

Advanced Emergency Braking (AEB) is a system that uses forward looking sensors such as Lidar, Radar, and/or Cameras to identify a risk of an imminent collision. It will typically first warn the driver of the risk and, if the driver does not react, apply braking automatically to avoid the collision or to reduce the collision speed and therefore the potential for injury.

This document sets out the guidance notes related to the fitment of AEB. These guidance notes are aimed at bus operators and OEMs as a practical guide for implementation of the Bus Safety Standard.

These notes are for guidance only and are not legally binding. In all circumstances, the guidance provided by an OEM or system supplier shall take precedence, and these guidance notes are only for use in the absence of other information. These are not intended to be exhaustive, but to point the operators toward practical advice and questions to raise with OEMs/suppliers.

For full understanding of this Attachment it should be read in conjunction with London Bus Services Limited New Bus Specification: Section 4.3.2, Attachment 15: AEB Assessment Protocol and Attachment 42: Complex Electronic Control Systems

2 Selection of buses/systems

Any bus that meets the TfL Bus Vehicle Specification.

AEB shall be provided on all new build buses and its performance shall be closely monitored in order to check that it is having the expected effects in terms of both true and false positive situations.

It shall not be retrofitted unless sufficient evidence can be provided to TfL that systems can be implemented safely and robustly.

2.1 Compliance and warranty

As part of the acceptance procedure for new buses, they will be tested against TfL's Test and Assessment protocol for AEB, Attachment 15. The protocol has been designed to appropriately balance true and false positive performance and, therefore, a higher score should always produce a better net number of casualties.

A bus operator should ask to see compliance certificates for UNECE Regulation 13 and warranty information for the brake system from the OEM and/or the AEB system supplier. The bus operator must be able to present certificates to TfL as evidence that the bus brake system will continue to operate safely.

An OEM should work with any brake or AEB system suppliers to ensure that UNECE Regulation 13 requirements are met, and that warranty on the brake system is



maintained. The OEM must be able to present certificates to TfL as evidence that the bus brake system will continue to operate safely.

2.2 Normal Operation

A bus operator should ask to see evidence of how well the system performs when it is activating in the situations it is intended to activate in. This should include the results and scoring from the AEB solution test and assessment protocol document. This protocol includes a variety of physical tests designed to assess the ability of an AEB system fitted to a bus to avoid or mitigate collisions with other road users while minimising risks to occupants of the bus from unnecessary brake interventions.

2.3 False positive activations

All AEB systems carry a risk that the sensors 'misjudge' a particular traffic situation such that a warning function or even automated braking are applied in a situation where it would not be intended to act, otherwise known as a false positive activation.

It is important that an AEB system causes as few braking events resulting from false positive activations as possible. The OEM shall target zero false positive activations and will need to demonstrate evidence to TfL that the vehicle is capable of driving for at least 300,000 km in mixed city traffic without any false positives.

A bus operator should ask to see the evidence from the OEM and/or AEB system suppliers that demonstrates that their vehicles have been rigorously tested and there is evidence to show the distance travelled during development of the AEB system without any false positive activations occurring. Such a test programme must cover an extensive range of environmental conditions, events and scenarios that are representative of those that could reasonably be expected to occur in service. This may involve documents showing how far has been driven in dense city environments for the base system used across different vehicles and specifically for the system as fitted to the specific bus in question and the number of false positive activations. The evidence can relate to the OEM's tuning process, in which case it is permissible for the system to have suffered a false positive activation if there is evidence to show that the algorithm was tuned to eliminate that effect and that this was demonstrated to work in a computer simulation using the actual sensor inputs recorded by the system when the activation first occurred.

2.4 False negatives

It should be noted that systems are not guaranteed to successfully detect an imminent frontal collision in all circumstances. There are some circumstances in which it is not designed to activate. Even in situations it is designed to activate in, unusual permutations of conditions can come together to cause it to fail to detect the object. These instances are known as false negatives.



2.5 Balancing risks

The TfL requirements are open and flexible. Although certain minimum standards must be met or it will fail to meet the requirements of the bus vehicle specification, there is still very considerable room for industry to choose the level of system performance that they think will work best for their particular operation. For example, TfL will attempt to commercially incentivise systems that maximise the potential to avoid collisions. However, some OEMs may produce systems that apply only partial braking in an emergency or differ in terms of the vehicle speed that the system will be active at. Operators should aim to consult different OEMs to identify any such differences, explain the rationale and then decide which best suits their corporate aims, balancing any incentives with the effect on any internal objectives.

2.6 Monitoring

AEB is new to the bus market and London will be a pioneer in implementing it. Any brake activation, human or automated, has the potential to cause injury to bus occupants. The AEB system cannot apply braking that is any more severe than a skilled driver could. However, in a false positive brake activation this creates a risk that would not exist if the advanced braking system did not exist. TfL has, therefore, mandated that if an AEB system is fitted, it must make data available for recording via the CCTV system or some other suitable method. A minimum set of data to be reported to TfL on a monthly basis has also been included in the specification.

It is very important that operators capture as much of this data as possible, monitor it closely and report it to TfL. Current practice with CCTV is that operators make a semi-permanent download of CCTV data every time there is an incident which the driver feels could result in a complaint or some form of claim. As a minimum, any observed activation of AEB should be considered as such an incident and result in data recording and retention and reporting to TfL.

However, the above system is reliant on the driver. In false positive activations, a full brake stop should be relatively rare. Most will be a very short duration stab on the brakes, very quickly released again. Drivers may not realise that it was caused by AEB and hence not report appropriately. Similarly in true positive situations where genuine collision risk existed, there may be an incentive for drivers not to report AEB activation because they may feel it would highlight some shortcoming in their driving. It would, therefore be preferable if the data provided by the AEB could trigger an automatic record and alert to the operator. This would ensure a more accurate assessment of the operational success of the system or alternatively flag any emerging problems earlier.

Where operators fit and use a standard telematics device for fleet management, it may be much more effective to ask the telematics supplier to integrate the provided AEB signal and record it as an 'event' in routine reporting such that rates per km as defined in the specification for new buses can be derived automatically and used to trigger downloading of CCTV with minimum effort.



3 Training

3.1 For test services

The AEB solution test and assessment protocol contains many similarities to the tests carried out on passenger cars by EuroNCAP and by regulatory authorities on HGVs. Therefore test houses accredited to undertake Euro NCAP tests or to undertake approval tests to UNECE Regulation 131 will be considered suitable to undertake performance tests. Test services without such accreditation will be required to demonstrate to TfL, at their own expense, that they can achieve the same standard of testing as an accredited organisation.

3.2 Bus drivers

An AEB system is only aimed at preventing rare occurrences where the driver has not already taken any/sufficient braking action in order to avoid an imminent collision. As such, the system should be entirely invisible to the drivers for the vast majority of their driving time.

In principle therefore, the drivers don't necessarily need to be trained in exactly how the system works. However, it may be beneficial to inform them how the system will operate, e.g. the specific audible and/or visual warnings, how the system will apply the vehicle's brakes, and any specific action(s), if any, required by the driver to return to normal driving following an activation. One key message for drivers is that this is a system of last resort, intended to work in situations that develop faster than they can reasonably react or where they have not been able to pay full attention to the risk for whatever reason. It does not replace any part of the driving task or their responsibility for safe operation of the vehicle and will not work in all circumstances, environments or weather conditions. Under no circumstances should they attempt to demonstrate its operation or rely on it to stop the vehicle in a situation they are capable of dealing with.

Unless automatic monitoring is implemented, drivers should be encouraged to report every activation of the system in whatever driving circumstance it occurs.

3.3 Shift Supervisors

Shift supervisors should be trained in how the system works and the monitoring and reporting requirements. In the event that the system develops a fault, then, unless the OEM advises differently, they should understand this as an 'amber' warning where the loss of capability is explained to the driver and the vehicle is taken out of service for repair as soon as possible. The system should fail safe in that it will simply stop providing the benefit rather than cause any new problems. As such it is not necessary to stop immediately (e.g. at the roadside) in the case of a warning light illuminating in the cab.

3.4 Bus maintenance engineers

The engineers carrying out general bus maintenance should be aware of the location and details of any sensors related to the AEB system. Training should be based on the OEMs' guidance. However, this is likely to include understanding the importance



of ensuring the sensors are correctly aligned, undamaged and unobstructed since the performance of the AEB system is completely contingent on the sensors the system is connected to.

A bus operator should ask the OEM and/or AEB system supplier to provide guidelines in the event that the windscreen/grille area in front of sensor becomes damaged, or if the performance of the system has degraded.

4 Maintenance

Operators are encouraged to establish what (if any) daily checks are required, and to plan for these additional operational costs. Each OEM will have a set of maintenance requirements for their systems. These can vary quite significantly between OEMs, and Operators should discuss these requirements with their suppliers to ensure that all of the implications are considered at the purchase stage and, thereafter, in routine operation. Most systems will require that the areas that sensors are installed in remain clean, undamaged and clear of any possible obstruction not part of the original design. In short, do not mount any ancillary equipment in the field of view of the sensors.

When damage occurs in the area of the sensor, it is possible that it may become misaligned and this can significantly impair AEB performance.

Some sensors can automatically self-align to some degree in order to compensate for minor disturbances. Others cannot and will require resetting after every disturbance. Once a sensor has been disturbed, most will require some form of reset and/or recalibration process. This process can vary substantially, from a simple software reset, through simple calibration processes easily undertaken in a workshop environment, to a need for very specialist equipment and/or large spaces to enable dynamic manoeuvres to be safely undertaken. This can have significant cost implications in the event of damage/disturbance. In particular, in the passenger car market it was found that some camera based systems required complex and expensive recalibrations after windscreen replacement whereas others did not require any intervention. Operators should check the specific requirements of the systems being offered by their suppliers with preference for self-aligning systems with low burden recalibration requirements.

5 Repair

If during system maintenance checks (4) any of the sensors are deemed to be faulty or failing they should be replaced as soon as possible. The AEB system's effectiveness and reliability is completely contingent on the performance of the sensors the system is connected to. However, unless the OEM advises to the contrary, the system should fail safe such that it is not necessary to stop the vehicle immediately, for example, at the side of the road. OEM guidelines in relation to the repair of the vehicle body and/or windscreen in the vicinity of sensors. For example, some may prohibit the use of body fillers or aftermarket components in front of a sensor.



Attachment 17: Intelligent Speed Assistance (ISA) Assessment Protocol

1 Introduction

This document presents a procedure for objectively assessing the performance of systems fitted to new buses in order to restrict their speed to within the prevailing speed limit. These systems are collectively known as Intelligent Speed Assistance (ISA).

ISA systems are provided to assist drivers to keep within the speed limit, but do not absolve the driver of this responsibility. These systems only act to limit the vehicle response to the accelerator pedal input whilst the bus is travelling within a speed limit zone and do not actively control the vehicle speed.

For full understanding of this Attachment it should be read in conjunction with the Attachment 18: Intelligent Speed Assistance (ISA) Guidance Notes and New Bus Specification, Section 4.3.3.

2 Scope

This protocol applies to all new buses intended for service under contract to TfL that are passenger vehicles with a maximum mass exceeding 5 tonnes and a capacity exceeding 22 passengers. The passenger vehicles will be capable of carrying seated but unrestrained occupants and standing occupants. Such vehicles are categorised the Consolidated Resolution on the Construction of Vehicles (R.E.3) as M₃; Class I.

3 Purpose

The purpose of this assessment is to test the ability of the ISA system fitted to a bus to restrict the speed of the bus to the prevailing speed limit. This protocol provides all parties involved (OEMs, test services, assessors) with instructions regarding the test and assessment of ISA systems.

4 Normative references

The following normative documents, in whole or in part, are referenced in this document and are indispensable for the correct application of this test and assessment protocol. For dated references, only the edition cited applies. For undated references, the latest edition of the referenced document (including any amendments) applies.

- London Bus Service Limited New Bus Specification Section 4.3.3
- London Bus Service Limited New Bus Specification – Attachment:18 Intelligent Speed Assistance (ISA) Guidance Notes



- UN ECE Regulation 39 Uniform Provision concerning the approval of vehicles with regard to the speedometer and odometer equipment including its installation

5 Definitions

For the purpose of this Protocol:

- **AA: Approval Authority** – The Approval Authority is the body within TfL that certifies that a bus is approved for use in the TfL fleet and assigns its score under the bus safety standard for use in procurement processes
- **ISA: Intelligent Speed Assistance** – system fitted to a vehicle to restrict its speed to the prevailing speed limit
- **ROM: Restricted Operating Mode** – A condition where the ISA system actively prevents acceleration beyond the prevailing speed limit
- **TS: Test Service** – The organisation undertaking the testing and certifying the results to the Approval Authority
- **Vehicle Speed** – Measurement of the vehicle speed shall be taken by the Test Service using the vehicle CAN. This measurement shall be used for all assessments and comparison to Target Speed and Speed limits. The CAN speed shall comply with the accuracy requirements of UN ECE Regulation 39 and shall be reflected on the Speedometer.
- **Target Speed** – The vehicle speed which must be achieved as defined in each Test procedure of this protocol. The vehicle speed must be maintained within ± 0.5 mph of any target speed defined during each test procedure.
- **Speed Limit** – The maximum acceptable vehicle speed within any specific zone of the Digital Speed Map. Should the VUT vehicle speed be 2mph greater than the Speed limit, the speed limit shall be said to have been exceeded.
- **Test Track** – Any sealed area of carriageway without general access to the public
- **Digital Speed Map** – An electronic map which indicates the speed limit of roads. This may be for On-Road use, provided by TfL, or Test Track, provided by ISA system supplier, OEM or TS.
- **OEM: Original Equipment Manufacturer** – The company responsible for the manufacture of a completed bus, delivered to a bus operator
- **Test Service:** The organisation undertaking the testing and certifying the results to the Approval Authority.
- **VUT: Vehicle Under Test** - means a vehicle that is being tested to this protocol.
- **Zone** – An area of the Digital Speed Map with a specified speed limit



6 Test Conditions

6.1 Test environment

The test procedure requires that the VUT is tested by driving it both in areas away from the public (referred to as a test track), and on the public highway.

A test track area shall be used by the TS which permits the various tests required (10mph, 20mph, 30mph, unrestricted). The coordinates and speed limits shall be provided to TfL which will incorporate the details into the TfL Digital Speed Map. The test track shall:

- a) Be a dry (no visible moisture on the surface), uniform, solid-paved surface with a consistent slope between level and 1%
- b) Be paved and shall not contain any irregularities (e.g. large dips or cracks, manhole covers) which might excessively slow the VUT.

An on-road route shall be devised by the TS which starts at least 1km outside the geographical area covered by the TfL Digital Speed Map., At one point within the TfL Digital Speed Map zone, the bus will be stopped and the system powered down, restarted and the journey continued. The route shall incorporate 20mph, 30mph, and 40mph sections with transitions between each.

6.2 Weather and lighting

Tests shall be conducted in conditions representative of year-round London weather. Permissible weather conditions for testing are decided at the discretion of the TS.

Wind speeds should be below 22mph (approx. 10m/s) to minimise the effect of wind on bus speed. In case of wind speeds above 11mph (approx. 5m/s) during test, the validity of the test is decided at the discretion of the TS using the OEM predicted performance.

7 Pre-test submissions

It is necessary for the TS to understand details of and make certain additions to the ISA system being tested. Therefore the following documentation shall be provided by the OEM prior to any testing:

- a) Full identification of the ISA system hardware and software versions, and the applicable model of bus
- b) A test vehicle with an indicator system (visible to the bus driver) that displays the maximum speed limit of the ISA system when in Restricted Operating Mode (ROM)
- c) Evidence from an appropriately certified body that the system has been tested and approved as per the requirements for Speedometer equipment within UN ECE Regulation 39
- d) A statement describing how the ISA system operates
- e) A written declaration that this ISA system does not have adverse effects on fuel consumption or emissions



- f) A statement regarding any relevant Type Approvals which apply to the ISA solution. If Type Approvals are not required then a statement of this shall be provided
- g) A description of the applicable iBus system type (1 or 2) and a schematic diagram of the GPS antenna connection to the ISA system
- h) Detail of London Buses' approval for use of the Radio Frequency splitter (if used)
- i) A schematic diagram and description of where the ISA system obtains the vehicle speed information
- j) A demonstration of the receipt of a speed signal from either the FMS or CAN to the ISA system
- k) A statement as to whether speed restriction is assisted by any system, and a description of the operation of this system
- l) A statement as to whether a function that provides an over-speed notification to the bus driver is fitted, and provide details of the form of this notification
- m) A statement that the vehicle performance characteristics are unaffected when the vehicle is not in Restricted Operating Mode
- n) Instructions regarding how the ISA system is enabled and disabled
- o) It is the responsibility of the test requester to ensure any vehicle tested for ISA provides a method to allow for the GPS, FMS and CAN signals received by the ISA system to be independently isolated. Modification of the relevant vehicle systems and/or cables may be allowed to provide this function during testing.
- p) A description of potential failure modes of the ISA system.
- q) A description of all mapping formats from the file format list provided in the London Bus Technical Specification which can be used on the ISA system.
- r) A statement regarding how any bus mapping can be updated on an ad-hoc basis.
- s) Instructions with/in the application for the updating of the Digital Speed Map, and include any equipment necessary to facilitate this updating for the test. It is the OEM's responsibility to ensure the correct digital map is uploaded prior to test. Two maps shall be provided, with different zones and speed limits as agreed with the test service. These may include one map for the off-road test track and another map for the on-road tests. This shall also include the description of how the map update is protected from unauthorised access.
- t) A declaration regarding any additional antenna for updating the digital speed map.
- u) Instructions and any necessary equipment to read and clear any ISA system fault. A list of possible faults and their codes shall be provided and guidance on how to trigger these faults.
- v) A photo of the ISA symbol as shown on the driver information screen.
- w) A photo of the speed limit symbol as shown on the driver information screen.



- x) A record shall be made of the method provided to inform the driver of ISA fitment. This may be by a photograph for visual methods such as a sticker or light, or by video recording for audio method such as a voice recording.
- y) If Routing Information is implemented to recover from temporary GPS loss and to enhance parallel road resolution, a statement indicating this functionality is supported should be attached so that the TS will be aware and take note of the GPS loss timing may be extended

8 System checks

A number of checks should be made by the Test Service whilst the vehicle is static. Support to achieve the following checks may be provided by the OEM or ISA system supplier where appropriate:

- a) The TS shall physically observe a cabled connection from the GPS antenna to the ISA system. The test shall be deemed to have failed if this cabled connection cannot be observed.
- b) Any speed retardation system declared by the OEM shall be investigated and observed by the TS.
- c) The TS shall enable and disable the system using the instructions provided by the OEM.
- d) The TS shall look for and attempt to non-destructively disable the system in those areas of the VUT accessible to the driver within a period of 2 minutes without tools. The system shall be deemed to fail this requirement if the ISA system can be disabled without tools within a 2 minute period.
- e) The TS shall observe if the following dash lamps are fitted:
 - i. Green – The system is functioning correctly within the Digital Speed Map area
 - ii. White – The vehicle is not within the Digital Speed Map area and/or there is loss of GPS signal
 - iii. Amber – The ISA system has a fault, for example with its communication (CAN or FMS) signal

The system shall be deemed to have failed unless all the dash lamps are present. Each lamp may be in the same position and simply change colour as relevant, with the fault warning taking precedence.

- f) The TS shall, if possible, trigger an ISA system fault. The illumination status of the green, white, and amber dash lamps shall be recorded. The system shall be deemed to have failed if the green lamp is not extinguished and the amber lamp is not illuminated when a system fault is caused.
- g) The TS shall interrogate the ISA system for the fault and record if it matches the caused fault. The system shall be deemed to have failed if the system fault recorded does not match the system fault caused. The OEM is responsible for providing a CANbus database file for the ISA system that details system states and faults.
- h) The ISA system supplier or OEM shall provide the TS with method to clear the fault from the system. Fault shall be cleared and the illumination status of the



amber light observed. The system shall be deemed to have failed if the system cannot be cleared and if the amber light does not extinguish.

- i) The TS shall review all mapping formats successfully load and correctly function by driving the vehicle on the off-road test track and testing for the correct application of 20mph and 30mph speed limits. The test shall be deemed to have failed if this information is not provided. The test shall be deemed to have failed if these mapping formats fail to properly load and apply.
- j) The TS shall observe that any outdated Digital Speed Map can be completely removed from the ISA system and replaced with an updated map. This test may require a computer connection to the ISA system to check upon file deletion and addition, and the system shall be deemed to have failed if outdated Digital Speed Maps cannot be completely removed.
- k) The TS shall assess an ad-hoc change to the Digital Speed Map. The system shall be deemed to have failed if in the assessment of the TS the bus Digital Speed Map cannot be updated on an ad-hoc basis.
- l) Addition of a specific antenna for updating the Digital Speed Map is prohibited. The presence of such an antenna shall result in test failure.

9 Test procedure

The vehicle speed for each test shall be measured and recorded from the vehicle CAN. This measurement shall be used for all assessments and comparison to Target Speed and Speed limits. The CAN speed shall comply with the accuracy requirements of UN ECE Regulation 39 and shall be reflected on the Speedometer.

Note: A check should be performed before starting each defined test to ensure the ISA is in the correct enabled/disabled condition applicable for the relevant test.

9.1 Track Testing

The following tests shall be undertaken at a suitable test track (see Section 6.1).

Where reasonable and appropriate the test service may assess multiple functions at the same time whilst still conforming to the procedures defined in this document. This may be conducted at the discretion of the test service, with prior agreement from the Approval Authority.

The VUT shall be driven on a test track whereby separate areas of the track are entered into the VUT's Digital Speed Map with speed limits of; 20mph, 30mph, 40mph and unrestricted.

Tests shall be conducted in an unladen condition with a driver (and observer if required).



9.1.1 Test Procedure

For all parts of the test, a tolerance of ± 0.5 mph is allowed for all speed limits prescribed.

9.1.1.1 Check ISA will impose a speed restriction as soon as all conditions of ROM are met.

The VUT shall be driven at a speed of 30mph whilst within a 30mph zone.

It shall enter into a 20mph zone with the accelerator pedal fully depressed and continue travelling with pedal fully depressed.

After entering the 20mph zone the ISA shall actively reduce the speed of the VUT in the manner described by the vehicle OEM.

9.1.1.2 Check of ISA that vehicle speed reduction has been achieved without intervention of braking.

Note: Deceleration produced by energy recovery and/or engine retardation up to the level of 0.70m/s^2 .

The VUT shall be driven at a speed of 30mph whilst within a 30mph zone.

It shall enter into a 20mph zone with the accelerator pedal fully depressed and continue travelling with pedal fully depressed.

After entering the 20mph zone the ISA shall actively reduce the speed of the VUT in the manner described by the vehicle OEM.

The VUT shall continue travelling with accelerator pedal fully depressed until vehicle speed remains stable at 20mph [± 0.5 mph] for the duration of at least 15 seconds.

9.1.1.3 Check of driver notification should ISA enforce any retardation of vehicle speed.

The VUT shall be driven at a speed of 30mph whilst within a 30mph zone.

It shall enter into a 20mph zone with the accelerator pedal fully depressed and continue travelling with pedal fully depressed for at least 15 seconds.

After entering the 20mph zone the ISA shall actively reduce the speed of the VUT in the manner described by the vehicle OEM.

Whilst the VUT is travelling in excess of zone speed limit and the ISA system is actively retarding the vehicle speed, the driver shall be notified. This may be via a flashing speed limit symbol and by a reduction in the indicated speed.

The flashing frequency of the speed limit symbol shall be between 1Hz and 5Hz



9.1.2 Other tests

The VUT shall be tested to the following procedures.

9.1.2.1 Check that the ISA system does not affect the operation of the VUT below the speed limit.

- a) The VUT shall be accelerated at full rate from 0mph within a 20mph zone.

The time taken to reach a vehicle speed of 16mph (equivalent to 80% of the zone's speed limit), shall be measured and recorded.

The ISA system shall then be disabled and the time taken to accelerate to the same speed shall be measured and recorded for the same section of track. (ISA system should be enabled after completing this measurement).

The system shall be deemed to have failed if the difference in times to accelerate to same vehicle speed (80% of the zone's speed limit) with and without the ISA activated is more than 10%.

This shall then be repeated within a 30mph zone measuring the time taken to achieve a vehicle speed of 24mph (80% of the zone's speed limit).

- b) The VUT shall be driven within a 20mph zone with the accelerator pedal fully depressed. The VUT shall be travelling at a constant 20mph limit.

It shall enter into a 30mph zone with the accelerator pedal fully depressed and continue travelling with pedal fully depressed, for at least 15 seconds.

The system shall be deemed to have failed if the measured VUT acceleration curve differs materially from the LBSL Attachment 43 derived acceleration curve presented in pre-test submission checks.

This shall then be repeated starting within a 30mph zone and entering into an unrestricted zone.

9.1.2.2 Check that the system is secure from tampering.

- a) It shall be possible for only qualified personnel to disable the speed limiting system and only when the ignition is on and the vehicle is stationary.
- b) The disabling of the system must be via an electronic device (e.g laptop, tablet or similar) connected to the vehicle or over-the-air (if this feature is available). Additional control using a telematics system to manage the fleet is optional. The system shall be deemed to have failed if the conditions of the test cannot be met and if it would be possible for unequipped/unauthorised disabling of the system.
- c) The TS shall check for the correct enabling and disabling of the ISA system by test driving the VUT in both conditions. The system shall be deemed to have failed if the ISA system does not properly enable or disable.
- d) On the specific VUT, USB port shall be installed to facilitate TS to disable or to change to a test map.



9.1.2.3 Check that in the event of loss of GPS, FMS and CAN signal the system will fail safe whereby no speed limits are implemented by the ISA system.

- a) The VUT shall be driven at a speed of 20mph whilst within a 20mph zone, with the accelerator pedal fully depressed for the duration of the test.

The GPS shall be isolated, see Section 7 q) to replicate a signal loss and the vehicle speed shall be observed for 15 seconds and recorded.

- The system shall be deemed to have failed if the ISA icon on the dash does not turn white after 5 seconds and $\geq 30\text{m}$ travelled after the GPS is isolated.
- The system shall be deemed to have failed if the VUT is recorded as reaching speeds above 20mph.

- b) The VUT shall be driven at a speed of 20mph whilst within a 20mph zone, with the accelerator pedal fully depressed, for at least 15 seconds, at the Test Service's discretion.

The driver shall apply the brakes to reach a vehicle speed of 14mph or less, before accelerating to a speed above 20mph.

The system shall be deemed to fail if:

- i. The VUT accelerates before a braking input is applied.

OR

- ii. The VUT fails to reach speeds above 20mph after reaching a vehicle speed of 14mph or less.

- c) Test 9.1.2.3(a) and 9.1.2.3(b) shall be repeated with the FMS isolated.

- For 9.1.2.3(a) the system shall be deemed to have failed if the ISA icon on the dash does not turn amber as soon as the FMS is isolated
- For 9.1.2.3(b) the system shall be deemed to have failed if:
 - The VUT accelerates before a braking input is applied.

OR

- The VUT fails to reach speeds above 20mph after reaching a vehicle speed of 14mph or less.

- d) Test 9.1.2.3(a) and 9.1.2.3(b) shall be repeated with the CAN isolated.

- For 9.1.2.3(a) the system shall be deemed to have failed if the ISA icon on the dash does not turn amber as soon as the CAN is isolated
- For 9.1.2.3(b) the system shall be deemed to have failed if:
 - The VUT accelerates before a braking input is applied.

OR

- The VUT fails to reach speeds above 20mph after reaching a vehicle speed of 14mph or less.



9.1.2.4 Check of the travelled distance before a change of the speed limit indicator when entering a speed limit zone. (Guard against spurious GPS inaccuracy)

- a) The VUT shall be driven at a speed of between 5mph and 10mph whilst within a 20mph zone.

It shall enter a 30mph zone whilst retaining the same vehicle speed.

Using the front of the bus as the reference point, the distance travelled within the 30mph zone before the indicator system displays the new speed limit shall be recorded in metres.

The system shall be deemed to have failed if the distance recorded less than 30.0m

- b) This test shall be repeated with the VUT travelling at a speed of between 5mph and 10mph whilst within a 30mph zone and entering into a 20mph zone.

9.1.2.5 Check of the time to indicate VUT having entered a ROM zone (Guard against spurious GPS inaccuracy)

- a) The VUT shall be driven at a speed of 20mph whilst within a 20mph zone for a time of at least 15seconds.

It shall enter into a 30mph zone whilst retaining the same vehicle speed.

The time taken once within the 30mph zone before the indicator system displays the new speed limit shall be recorded.

The system shall be deemed to have failed if the time recorded is less than 5.0seconds and greater than 8.0second.

- b) This test shall be repeated with the VUT travelling at 30mph whilst within a 30mph zone and entering into a 20mph zone.

9.1.2.6 Check the indication that the VUT has entered or exited the digital map area

- a) The VUT shall be driven at a speed of 20mph from outside of the Digital Map Area for a time of at least 15 seconds

It shall enter into the Digital Map Area.

The time and the distance travelled before the dash lamp displays that the VUT has entered the Digital Map Area shall be recorded.

The system shall be deemed to have failed if the time recorded is less than 5.0seconds and greater than 8.0seconds ($5 < t < 8$) OR the distance travelled was less than 30.0m.

- b) This test shall be repeated with the VUT travelling from inside the Digital Map Area and exiting it. The time and distance constraints defined in section 9.1.3.6a do not apply to this test.



9.1.2.7 Check of the continuous illumination of the green dash lamp

- a) The VUT shall be driven at a speed of 20mph whilst within a 20mph zone with the accelerator pedal fully depressed, for a time of at least 15 seconds.

It shall enter into a 30mph zone continue to travel with the accelerator pedal fully depressed for a distance of at least 100m.

The illumination status of the green dash lamp shall be recorded.

The system shall be deemed to have failed if the continuous green lamp extinguishes during the test.

- b) This test shall be repeated with the VUT travelling from a 30mph zone into a 20mph zone.

9.1.2.8 Check for indication of VUT being outside of the Digital Map Area

Whilst outside of the Digital Map Area by a distance of greater than 100m the vehicle shall be started and driven. The VUT shall remain outside of the Digital Map area and complete at least 100m travel.

The status of the dash lamps indicating ISA status shall be recorded.

The ISA system shall be deemed to have failed if the green lamp is not extinguished AND the white lamp is not illuminated at all times.

9.1.2.9 Check for dash indication with ISA system disabled

Whilst outside of the Digital Map Area the ISA system shall be disabled.

The VUT shall then be driven into the Digital Map Area by for a distance of at least 100m and then driven at least 100m out of the Digital Map Area.

The status of the green and white dash lamps shall be recorded.

The ISA system shall be deemed to have failed if at any time the green lamp is illuminated OR the white lamp is extinguished.

9.1.2.10 Check “No Digital Speed Map” condition

The TS shall ensure that when there is no Digital Speed Map loaded on to the VUT there is no system activation and no speed restriction exists.

The ISA system shall be deemed to have failed if a speed restriction is found on a bus with no Digital Speed Map loaded on to the system.

9.1.2.11 Check VUT restricted speeds against Digital Speed Map speed limits

- a) The TS shall ensure the maximum vehicle speeds achievable whilst within each zone are the same as the speeds limits defined in the Digital Speed Map

The VUT shall be deemed to have failed if the maximum vehicle speed achievable for any zone is found to be different to those expected from the loaded map.

- b) Test to be repeated using an alternative Digital Speed Map which consists of different zones and limits to ensure the speed restrictions have subsequently changed



Note: It may be useful to ensure that the zones and speed limits are clearly mapped against features/markers.

9.2 On road testing

On road testing shall only be commenced upon successfully achieving all requirements defined for track testing.

The VUT shall be driven on the on road testing infrastructure as defined in Section 6.1

Tests shall be conducted in an unladen condition with a driver (and observer if required).

Note: The TS shall pre-determine a route for this test. It is prudent to choose times of day when the speed limits may be reached, and which limit risk (for example times when vulnerable children are less likely to be present).

Note: The TS shall create a printed map of the route using speed limit information from the applicable Digital Speed Map to allow test observer who is not the driver to cross reference actual location to the Digital Speed Map and the maximum speed limit indicator.

Note: The TS shall record the route using a separate GPS system and use a map of the route to assist with identifying each part of the test.

Note: A duplex video camera system, with one view of the speedometer and the other of the road ahead can assist in determining speed, location, and speed exceedances. Video is to be time aligned during test to speed and position data within the TS data acquisition software.

9.2.1 Check VUT restricted speeds against Digital Speed Map speed limits

The TS shall ensure the maximum vehicle speed achievable whilst within each zone are the same as the speed limit defined in the Digital Speed Map

The VUT shall be deemed to have failed if the maximum vehicle speed achievable for any zone is found to be different to those expected from the loaded map.

Note: Speed limit shall only be achieved when and where safe to do so.

9.2.2 Check of the travelled distance and time before a change of the speed limit indicator when entering a speed limit zone

A visual comparison of the digital speed limit map and the speed limit indicator shall be made as the VUT enters each speed limit zone.

The system shall be deemed to have failed if the time recorded is less than 5.0 seconds and greater than 8.0seconds ($5 < t < 8$) OR the distance travelled was less than 30.0m.



9.2.3 **Check ISA will impose a speed restriction as soon as all conditions of ROM are met**

Whilst the VUT is within a zone and has at any point travelled at a speed less than the speed limit, the ISA system will be expected to prevent the vehicle from exceeding the speed limit.

The system shall be deemed to have failed if the VUT exceeds the zone speed limit by greater than 2mph. Note: This shall not apply where the VUT is travelling downhill.

10 **Assessment of results**

The following criteria will be used to assess if the ISA system has passed or failed the assessment.

10.1 **Pre-test submissions**

In order to receive a “Pass” certification the system must receive a “Pass” grade for each of the requirements on the assessment checklist.

The system shall be deemed to have failed the assessment if it received a single “Fail” grade on the pre-test submissions checklist.

10.2 **System checks**

In order to receive a “Pass” certification the system must receive a “Pass” grade for each of the requirements on the assessment checklist.

The system shall be deemed to have failed the assessment if it received a single “Fail” grade on the system checks checklist.

10.3 **Track tests**

In order to receive a “Pass” certification the system must receive a “Pass” grade for each of the requirements on the assessment checklist.

The system shall be deemed to have failed the assessment if it received a single “Fail” grade on the track testing checklist.

10.4 **On-road tests**

In order to receive a “Pass” certification the system must receive a “Pass” grade for each of the requirements on the assessment checklist.

The system shall be deemed to have failed the assessment if it received a single “Fail” grade on the on-road testing checklist.

10.5 **Overall Assessment**

In order to receive an overall “Pass” certification the ISA system must receive a “Pass” grade for each of the above sections on the checklists

The system shall receive an overall “Fail” grade in the assessment if a single “Fail” grade was awarded on any section of the assessment checklists.



To integrate this pass/fail test into the overall bus safety score an overall Pass will be deemed as a score of 100% and a fail will be deemed a score of 0%

11 Test Report

The TS shall provide a comprehensive test report that will be made available to the AA. The test report shall consist of six distinct sections:

- a) Completed pre-test submissions checklist
- b) Completed system checks checklist
- c) Completed track tests checklist
- d) Completed on-road tests checklist
- e) Reference information

The reference information required includes as a minimum:

- a) Vehicle make
- b) Vehicle model
- c) Vehicle model variant
- d) ISA Hardware version
- e) ISA Software version
- f) iBus version (1 or 2)
- g) Applicable mapping types
- h) Details of the TS
- i) Test date(s)
- j) Statement from OEMs that the unit makes use of Routing Information



Appendix A - Pre-test submissions checklist

Details found in Section 7.

	Pre-test submissions	Pass/Fail
1	Full identification of the ISA system hardware and software versions, and the applicable model of bus provided by the bus OEM.	
2	A test vehicle provided by the bus OEM with an indicator system (visible to the bus driver) that displays the maximum speed limit of the ISA system when in restricted operating mode.	
4	A statement provided by the bus OEM describing how the ISA system operates.	
5	A written declaration provided by the bus OEM that this ISA system does not have adverse effects on fuel consumption or emissions.	
6	A statement provided by the bus OEM regarding any relevant type approvals which apply to the ISA solution. If type approvals are not required then a statement of this shall be provided.	
7	A description provided by the bus OEM of the applicable iBus system type (1 or 2) and a schematic diagram of the GPS antenna connection to the ISA system.	
8	Detail of London Buses' approval for use of the Radio Frequency splitter (if used) used as part of the ISA system.	
9	A schematic diagram and description of where the ISA system obtains the vehicle speed information, provided by the bus OEM.	
10	A physical demonstration of the receipt of a speed signal from either the FMS or CAN to the ISA system, provided by the bus OEM	
11	A statement has been provided by the bus OEM in their application confirming: No intervention by the brakes to enforce a speed restriction, however energy recovery and engine retardation is permitted.	
12	A statement has been provided by the bus OEM of if speed restriction is assisted by any system, and to describe the operation of this system.	
13	A statement has been provided by the bus OEM of if an over-speed notification to the bus driver function is fitted, and provide details of the form of this notification.	
14	A statement has been provided by the bus OEM that the vehicle performance characteristics are unaffected when the vehicle is not in restricted operating mode.	
15	A statement has been provided by the bus OEM that the vehicle has used Routing Information	
16	Instructions are provided by the bus OEM regarding how the ISA system is enabled and disabled.	
17	The bus OEM has provided a test vehicle where the GPS, FMS and CAN speed signals in to the ISA system can be independently isolated. Included must be clarification of how this has been achieved and how to isolate each signal.	
18	The bus OEM has provided a description of potential failure modes of the ISA system.	



	Pre-test submissions	Pass/Fail
19	The bus OEM has provided a description of all mapping formats from the list which can be used on the ISA system.	
20	The bus OEM has provided a statement regarding how any bus mapping can be updated on an ad-hoc basis.	
21	The bus OEM has provided adequate instructions with/in the application for the updating of the digital speed map, and include any equipment necessary to facilitate this updating for the test. This shall also include the description of how the map update is protected from unauthorised access. Two off-road test track-specific maps shall be provided, with different zones and speed limits as agreed with the test body.	
22	The bus OEM has provided a declaration in their application regarding any additional antenna for updating the digital speed map.	
23	The bus OEM has provided instructions and any necessary equipment to read and clear any ISA system fault. A list of possible faults and their codes shall be provided and guidance on how to trigger these faults.	
24	A photo of the ISA symbol as shown on the driver information screen.	
25	A photo of the speed limit symbol as shown on the driver information screen.	
26	A copy of the ISA fitment information to the driver (sticker, light, voice instruction etc), in a suitable format.	
27	Evidence, including a compliant acceleration curve has been supplied by the OEM derived from testing against LBSL Attachment 43: Bus Acceleration Performance Assessment Protocol.	

Result:



Appendix B - System checks.

Details found in Section 8.

	System Checks	Pass/Fail
1	The cabled connection from the GPS antenna to the ISA system can be observed.	
2	If a speed retardation system was declared by the bus OEM, then it was investigated and observed by the test service.	
3	The system can be enabled and disabled by using the instructions provided by the Bus OEM.	
4	The ISA system could not be non-destructively disabled without tools within a 2 minute period.	
5	The green dash lamp, white dash lamp and an amber dash lamp are all fitted for the ISA System.	
6	A triggered ISA system failure due to CAN or FMS isolation caused the green lamp to extinguish and the amber lamp was illuminated. Check there was no Audio alert	
7	Interrogation of the ISA system for the fault found a match to the caused fault.	
8	The fault can be cleared from the system.	
	The amber light was extinguished when the fault was cleared.	
9	The mapping format loaded and applied properly.	
	The correct application of 20mph and 30mph speed limits with applicable mapping formats was observed. Check there were no Audio alerts	
10	The outdated Digital Speed Map can be completely removed from the ISA system.	
	A new map can be uploaded properly.	
11	An ad-hoc change to the Digital Speed Map can be properly uploaded.	
12	No additional antenna for updating the Digital Speed Map is found.	

Result:



Appendix C - Track testing checklist

Details found in Section 9.

		Track testing	Pass/Fail
Tests	1	Check ISA will impose a speed restriction as soon as all conditions of ROM are met Check there were no Audio alerts	
	2	Check of ISA that vehicle speed reduction has been achieved without intervention of braking.	
	3	Check of driver notification should ISA enforce any retardation of vehicle speed. Check there were no Audio alerts	
Other tests	1	Check that the ISA system does not affect the operation of the VUT below the speed limit.	
	2	Check that the system is secure from tampering	
	3	Check that in the event of loss of GPS signal the system will fail safe whereby no speed limits are implemented by the ISA system Check there were no Audio alerts	
	4	Check of the travelled distance before a change of the speed limit indicator when entering a speed limit zone. (Guard against spurious GPS inaccuracy)	
	5	Check of the time to indicate VUT having entered a ROM zone (Guard against spurious GPS inaccuracy)	
	6	Check the indication that the VUT has entered or exited the digital map area Check there were no Audio alerts	
	7	Check of the continuous illumination of the green dash lamp	
	8	Check for failure indication of GPS, FMS and CAN Check there were no Audio alerts	
	9	Check for indication of VUT being outside of the Digital Map Area Check there were no Audio alerts	
	10	Check for dash indication with ISA system disabled Check there were no Audio alerts	
	11	Check "No Digital Speed Map" condition	
	12	Check VUT restricted speeds against Digital Speed Map speed limits	

Result:



Appendix D - On-road testing checklist

	On road testing	Pass/Fail
1	Check VUT restricted speeds against Digital Speed Map speed limits	
2	Check of the travelled distance and time before a change of the speed limit indicator when entering a speed limit zone	
3	Check ISA will impose a speed restriction as soon as all conditions of ROM are met	

Result:



Attachment 18: Intelligent Speed Assistance (ISA) Guidance Notes

1 Introduction

This document sets out the guidance notes related to Intelligent Speed Assistance. This system provides an aid to the driver, limiting the vehicle speed whilst travelling in designated speed limit zones.

These guidance notes are aimed at bus operators and OEMs as a practical guide for implementation of the Bus Safety Standard.

These notes are for guidance only and are not legally binding. In all circumstances, the guidance provided by an OEM or system supplier shall take precedence, and these guidance notes are only for use in the absence of other information. These are not intended to be exhaustive, but to point the operators toward practical advice and questions to raise with OEMs/suppliers.

For full understanding of this Attachment it should be read in conjunction with London Bus Services Limited New Bus Specification: Section 4.3.3 and Attachment 17 – ISA Assessment Protocol.

1.1 ISA Description

Intelligent Speed Assistance (ISA) is a system fitted to buses which links an understanding of location (from GPS¹) to an on-board map of speed limits (known as the TfL Digital Speed Map), and a reading of the bus speed. It uses this information to limit the speed of the bus without intervention by the foundation brakes to enforce a speed restriction, however energy recovery and engine retardation is permitted.

The Digital Speed Map will be created and updated by Transport for London, and it will be the responsibility of the bus operator to update the maps in buses either on a periodic timeline, or if directed an emergency timeline. It is advised that the bus operator keeps records of the date and version number of any uploaded Digital Speed Map against each bus.

The GPS accuracy of the ISA system shall be within 20 metres. Vehicles fitted with ISA can exceed the speed limit, for example in locations where gravity (typically downhill) will allow the bus to exceed the speed limit, or where the bus enters a lower speed limit. It is also likely in some circumstances for there to be a time lag between the implementation of a speed limit and the updating of the Digital Speed Map, and this is certainly likely to be the case for temporary speed restrictions such as roadworks.

¹ GPS = Global Positioning System. GPS is a global navigation satellite system that provides geolocation and time information to a GPS receiver anywhere on or near the Earth where there is an unobstructed line of sight to four or more GPS satellites. It allows the position of the bus to be identified in real time.



Driving at the speed limit is not always appropriate for the road curvature, surface, traffic, environmental conditions etc. **The driver is responsible for the vehicle speed and compliance with road speed limits at all times. ISA does not absolve the driver of responsibility for remaining within the speed limit.**

Below the speed limit the ISA has no impact upon the speed, acceleration, or any other operation of the bus.

When entering a lower speed limit it is the driver's responsibility to reduce the vehicle speed. The ISA system will not brake or use the vehicle's foundation brakes.

When entering a higher speed limit the vehicle will not increase speed automatically. Speed will only increase in response to the level of pressure on the accelerator pedal. It is the driver's responsibility to accelerate safely and only when conditions are appropriate.

The system cannot anticipate speed changes. For example it will not begin slowing down in advance of a lower speed limit sign.

2 Selection of buses/systems

ISA shall be fitted on new-build buses, conforming with with the performance requirements detailed in Section 4.3.3 of the LBSL Bus Vehicle Specification and as tested against LBSL Attachment 17.

A further variation can be the retrofit of ISA to in-service vehicles in some circumstances. The use of aftermarket equipment is authorised on the condition if it is a vehicle OEM integrated solution and complies with all performance requirements of the ISA specification prior to the homologation process. Only with express written approval from the Approval Authority within TfL, in the instance where an OEM has confirmed they have no intent to fit or support retrofit, will the use of aftermarket equipment be allowed.

It is anticipated that a future version of iBus provided by TfL will integrate ISA, so this is worth considering when selecting a supplier.

3 Training

3.1 Driver training

Training of drivers should entail at least the following elements:

- How the bus will operate
- How to understand the various warning lights
- What happens when transitioning between speed limits
- Limitations of the system, operating limits
- Clear emphasis that the driver remains responsible for speed limit compliance at all times.

The ISA supplier should provide specific material or advice which is appropriate to the system.



3.2 Maintenance training

It is expected that the bus operator will update the Digital Speed Map on each bus, and if this is the case then bus operator staff should be suitably trained to do so.

It is envisaged that the ISA supplier/Bus supplier will offer suitable maintenance training, covering at a minimum; map updating, and enabling and disabling the system. Additionally and depending upon any warranty and maintenance agreement, training may extend to fault finding/repair.

4 Maintenance

The ISA systems are specified so that they may not be easily interfered with by the driver. The bus driver is not expected to undertake any maintenance.

The bus operators and the ISA supplier/Bus supplier will reach an agreement regarding responsibility for ISA system maintenance and repair, and that any personnel undertaking maintenance are suitably trained and have access to any relevant documentation (such as schematics, fault-finding, parts lists, fitment details).

Suitably trained and authorised persons (who are not the driver) within the bus operator will be able to disable the ISA system if required and should be provided with any relevant tools or software/hardware to enable this. **However, the ISA system shall not be disabled on any in-service vehicle unless it has been demonstrated that there is a safety issue and TfL has agreed for ISA to be disabled.**

An inhibiting solution may be required to be uploaded on certain vehicles under the instruction of TfL. If Connected Services are active, the ISA system can be inhibited on an individual vehicle or a group of vehicles by uploading an inhibitor map or by using a configuration parameter.



Attachment 19: Bus Vision Standard

Assessment Protocol

1 Introduction

This document presents a procedure, hereon referred to as the Bus Vision Standard (BVS), for objectively measuring the vision that the driver has of the environment in close proximity to a bus, both directly via the windows/windscreen and indirectly via mirrors and/or camera-monitor systems (CMS).

For full understanding of this Attachment it should be read in conjunction with the Attachment 20: Bus Vision Standard Guidance Notes and New Bus Specification, Section 4.3.4.3.

2 Scope

This protocol applies to all new buses intended for service under contract to TfL that are passenger vehicles with a maximum mass exceeding 5 tonnes and a capacity exceeding 22 passengers. The passenger vehicles will be capable of carrying seated but unrestrained occupants and standing occupants. Such vehicles are categorised in the Consolidated Resolution on the Construction of Vehicles (R.E.3) as M₃; Class I.

3 Purpose

The aim of the Bus Vision Standard (BVS) assessment protocol is to provide an objective assessment that can be used to quantify the vision performance of a bus, enforce minimum standards and encourage performance over and above these minimum standards, while still permitting beneficial innovations (e.g. replacing mirrors with camera-monitor systems (CMS)) without adversely affecting safety.

Over many years blind spots in a driver's vision have been identified as a contributory factor in collisions between vehicles and pedestrians and cyclists which resulted in death or seriously injury. The BVS has been defined to reduce likelihood of these type of collisions.

Typically, direct vision blind spots in buses are caused by the A-pillars of the bus, the pillars around and at the centre of the front doors, the driver assault screen and by equipment in the driver cabin. Indirect vision areas rear of the driver seat position and for wider fields of view may also be subject to blind spots

It should be noted that the BVS is designed around collision situations relating to low speed, close proximity manoeuvres. It does not assess the vision required for higher speed manoeuvres and so scoring well does not absolve the OEM from the responsibility to design appropriate vision for all circumstances.



4 Normative References

The following normative documents, in whole or in part, are referenced in this document and are indispensable for its correct application. For dated references, only the edition cited applies. For undated references, the latest edition of the referenced document (including any amendments) applies.

- London Bus Services Limited New Bus Specification: Section 4.3.4.3
- London Bus Services Limited New Bus Specification: Attachment 20 Bus Vision Standard Guidance Notes
- Directive 2007/46/EC of the European Parliament and of the Council establishing a framework for the approval of motor vehicles and their trailers, and of systems, components and separate technical units intended for such vehicles.
- European Tyre and Rim Technical Organisation (ETRTO) Standards Manual
- Regulation (EU) 2018/858 of the European Parliament and of the Council of 30th May 2018 on the approval and market surveillance of motor vehicles and their trailers, and of systems, components and separate technical units intended for such vehicles, amending Regulations (EC) No 715/2007 and (EC) No 595/2009 and repealing Directive 2007/46/EC.
- SAE J182 (2015) “Motor Vehicle Fiducial Marks and Three-dimensional Reference System”.
- SAE J1100 (2009) “Motor Vehicle Dimensions”.
- SAE J1516 (2011) “Accommodation Tool Reference Point for Class B Vehicles”.
- SAE J1517 (2011) “Driver Selected Seat Position for Class B Vehicles - Seat Track Length and SgRP”.
- UN ECE Regulation 107 Uniform provisions concerning the approval of category M₂ or M₃ vehicles with regard to their general construction.
- UN ECE Regulation 46 Uniform provisions concerning the approval of devices for indirect vision and of motor vehicles with regard to the installation of these devices.

5 Definitions

For the purpose of this Protocol:

- **Accelerator Heel Point (AHP)** - A point on the shoe located at the intersection of the heel of shoe and the depressed floor covering, when the shoe tool is properly positioned. (Essentially, with the ball of the foot contacting the lateral centre line of the undepressed accelerator pedal, while the bottom of the shoe is maintained on the pedal plane). As defined in SAE J1516, SAE J1517 and SAE J1100.
- **AHP height** - Vertical height in the Z axis between the ground plane and AHP.



- **Ambinocular vision** - The total combined field of view that can be seen by at least one eye.
- **Angle of incidence** - The angle which a sightline makes with a plane that is angled perpendicular to the surface at the obstruction point. At the point where a sightline intersects a surface (Obstruction point), the angle between the sightline and a plane perpendicular to the surface at the Obstruction point
- **Approval Authority** - The body within TfL that certifies that a bus is approved for use in the TfL fleet and assigns its score under the bus safety standard for use in procurement processes.
- **Assessment zone** - The volume around the vehicle under test defining the volume of space that needs to be seen by the driver in order to view vulnerable road users within the area of greatest risk. The assessment zone is defined by collision data and by the UN ECE Regulation 46 indirect field of vision requirements.
- **Assessment zone element** - An element of known volume, and with no single dimension exceeding 0.1m, that forms part of the overall assessment zone volume.
- **Blind spot** - A blind spot is a volume of space around the vehicle under test that cannot be seen by a driver either through the daylight opening (DLO) or through the indirect vision devices installed on the vehicle.
- **Blind spot volume** - The proportion of the assessment zone that cannot be seen by the driver through either the direct or indirect fields of view.
- **Bus vision standard performance score** - The proportion of each assessment zone visible to the driver through the direct field of view.
- **Camera** - A device that renders an image of the outside world and converts this image into a signal (e.g. video signal).
- **Camera point** - A point representing the origin of the field of view of a camera.
- **Camera-monitor system (CMS)** - An indirect vision device where the field of vision is obtained by means of a UN ECE Regulation 46 certified combination of camera and monitor systems.
- **Coordinate system** - The three-dimensional vehicle coordinate system that is established in SAE J182.
- **Daylight opening (DLO)** - An area of a vehicle, windscreen or other glazed surface whose light transmittance measured at right angles to the surface is not less than 70%. As defined in UN ECE Regulation 125.
- **Direct field of view** - The field of view seen without the aid of any additional devices.
- **Direct vision volume** - The proportion of the assessment zone visible to the driver through the direct field of view.
- **Direct vision performance score** - The proportion of each assessment zone visible to the driver through the direct field of view.



- **ETRTO** - European Tyre and Rim Technical Organisation.
- **Eye points (E_L, E_R)** - Two points representing the driver's left and right eyes. These are the points from which sightlines originate.
- **Gross vehicle weight (GVW)** - The maximum permitted mass of a vehicle when fully loaded.
- **Ground plane** - Horizontal plane, parallel to the XY plane, at ground level.
- **Indirect field of view** - The field of view seen through the aid of an additional device such as mirrors or camera-monitor systems (CMS).
- **Indirect vision volume** - The proportion of the assessment zone visible to the driver through the indirect field of view.
- **Indirect vision performance score** - The proportion of each assessment zone visible to the driver through the indirect field of view.
- **Monitor** - A device that converts a signal into images that are rendered into the visual spectrum.
- **Monocular vision** - The total field of view that can be seen by a single eye or camera.
- **Neck pivot point (P)** - Point about which a driver's head turns on a horizontal plane.
- **Obstruction point** - A point located on the vehicle structure that obstructs the driver field of view.
- **OEM: Original Equipment Manufacturer** – The company responsible for the manufacture of a completed bus, delivered to a bus operator
- **Reference eye point (E_{ref})** - Midpoint between left and right eye points at centre line of driver.
- **Reflection point** - A point located on a mirrored surface that reflects the driver field of view.
- **Sightline** - A line representing the driver's line of sight from an eye point to an obstruction point, reflection point or a given angle.
- **Test service** - The organisation undertaking the testing and certification of the results to the Approval Authority.
- **Total driver vision volume** - The proportion of the assessment zone visible to the driver through either the direct or indirect fields of view.
- **Vehicle length** - The distance in the X axis between two points located at the foremost and rearmost aspect of the vehicle structure, excluding all features listed in Appendix A.
- **Vehicle structure** - All relevant vehicle glazing and bodywork, excluding all features listed in Appendix A.
- **Vehicle under test (VUT)** - The vehicle tested according to this protocol.



- **Vehicle width** - The distance in the Y axis between two points located at the most lateral aspects of the vehicle structure coincident to the first axle, excluding all features listed in Appendix A.

6 Test conditions

6.1 Coordinate System

A global coordinate system (X, Y, Z) for the VUT shall be defined such that the X axis is positive toward the front of the vehicle, the Y axis towards the left (nearside) and the Z axis upwards, as shown in Figure 19_1.

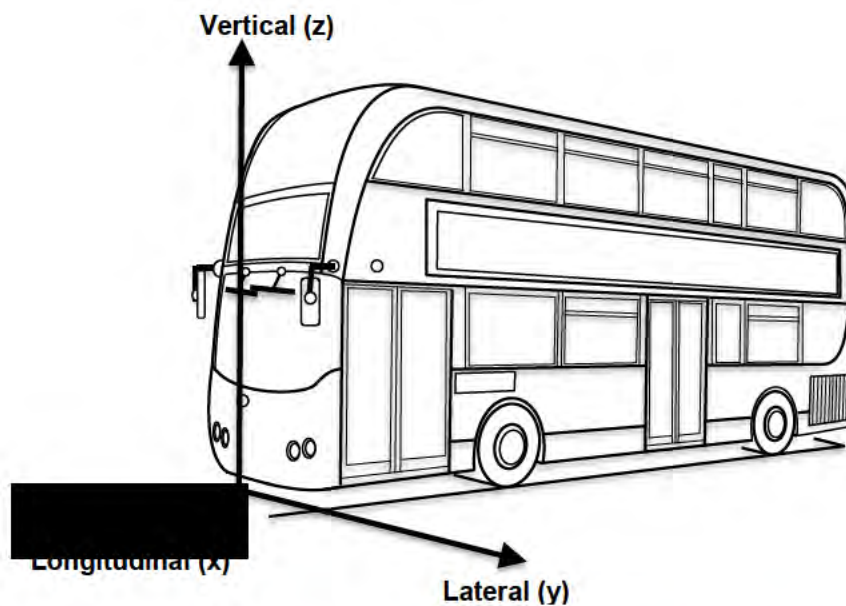

Figure 19_1: Global coordinate system and notation

The origin of the co-ordinate system shall lie on the ground plane, on the lateral centre line of the vehicle at the foremost point of the vehicle structure.

6.2 Eye Points

The field of view of the driver shall be defined by a cyclopean monocular vision point (E_C) taken as the mid-point between two eye points (E_L and E_R). Rotation shall be possible about a neck pivot point (P). E_L , E_R and P locations are defined in relation to the E_{ref} position, which in turn is defined in relation to the AHP.

6.3 Reference Eye Point Location (E_{ref})

The reference eye point (E_{ref}) is defined as an offset from the AHP of 0.678 m in the X axis and 1.16325 m in the Z axis, as shown by Figure 19_2. The reference eye point position in the X/Z-axes (E_{ref_x} , E_{ref_z}) shall therefore be positioned relative to the AHP position (AHP_x , AHP_z) according to the following equations:

$$E_{ref_x} = AHP_x + 0.678 \text{ m}$$

$$E_{ref_z} = AHP_z + 1.16325 \text{ m}$$

The reference eye point position in the Y axis (E_{ref_y}) shall be located in line with the central plane of the driver seat.

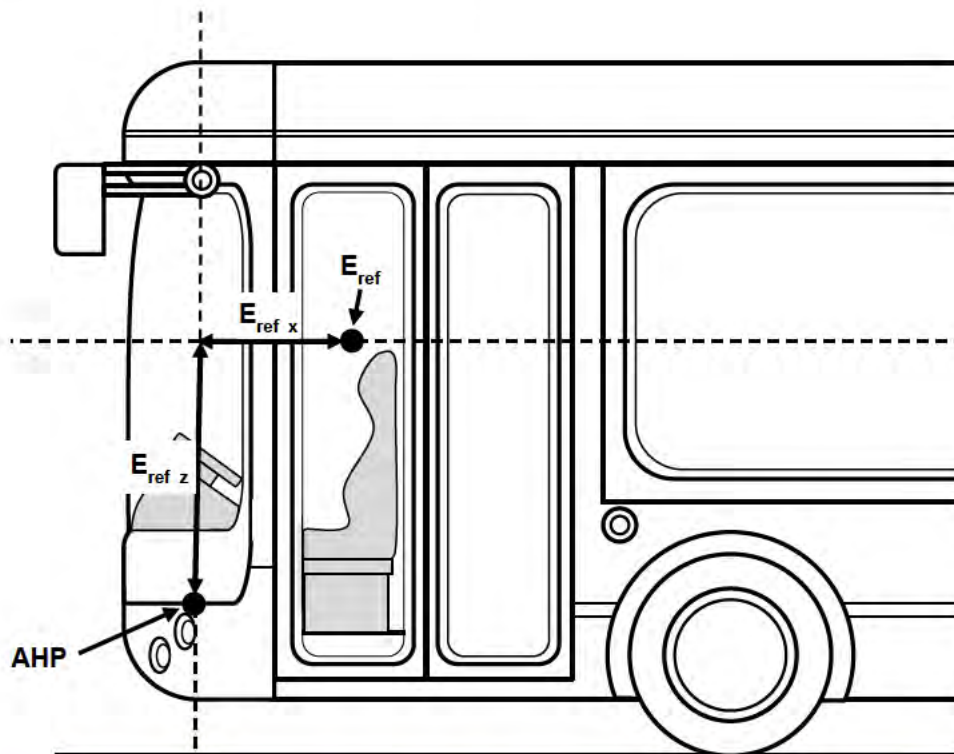

Figure 19_2: Definition of vertical (E_{ref_z}) and rearward (E_{ref_x}) offset of the reference eye point (E_{ref}) from the accelerator heel point (AHP)

6.4 Neck Pivot Point Location (P)

The neck pivot point (P) is defined as an offset of 0.098 m behind the E_{ref} point in the X axis, as shown in Figure 19_3.

6.5 Left and Right Eye Point Locations (E_L , E_R)

The left and right eye points (E_L and E_R) are defined as an offset of ± 0.0325 m from the E_{ref} point in the Y axis, as shown in Figure 19_3.

E_L and E_R are not required to defined the sightlines or vision volumes using the method defined in this document but are included for completeness.

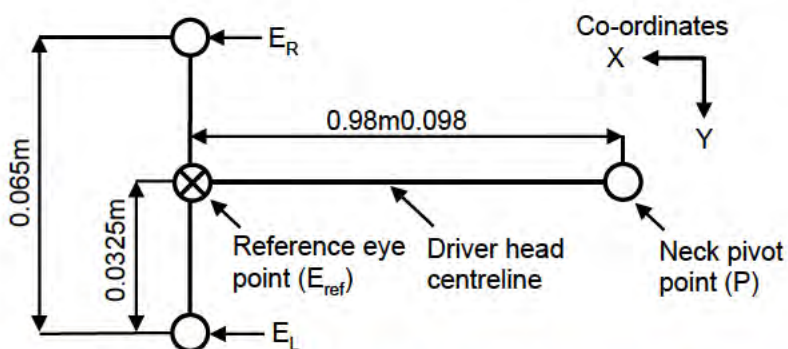

Figure 19_3: Definition of left and right eye point (E_L and E_R) positions relative to the neck pivot point (P) and reference eye point (E_{ref})

6.6 Neck Pivot Point Range of Motion (β)

The horizontal rotation (β) of the neck pivot point, which determines the relative motion of the eye points, is defined by a maximum range of motion of $\pm 90^\circ$ rotation about the neck pivot point (P), as shown in Figure 19_3.

There shall be no vertical rotation about the neck pivot point.

6.7 Eye Point Range of Motion (θ)

The horizontal rotation (θ_L , θ_R) for the Eye point E_C is defined by a maximum range of motion of $\pm 30^\circ$, as shown in Figure 19_4.

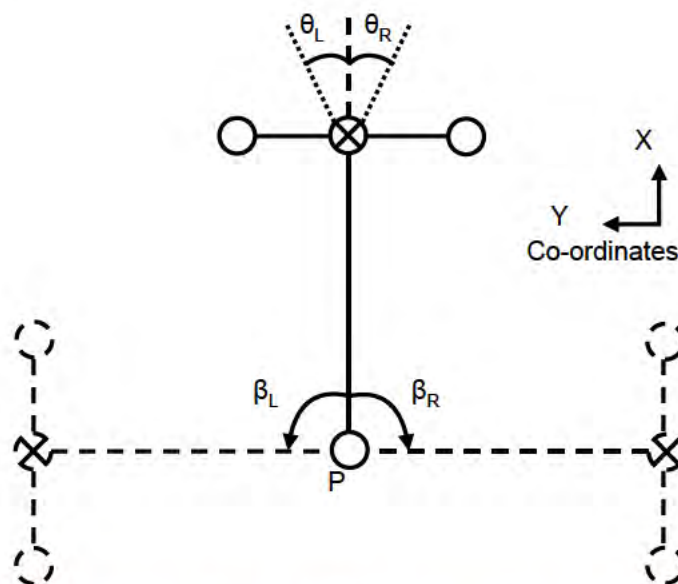

Figure 19_4: Plan view of horizontal neck point and eye point rotations

The vertical rotation (θ_U , θ_D) for the eye point is defined by a maximum range of motion of 45° upwards and 60° downwards as shown in Figure 19_5.

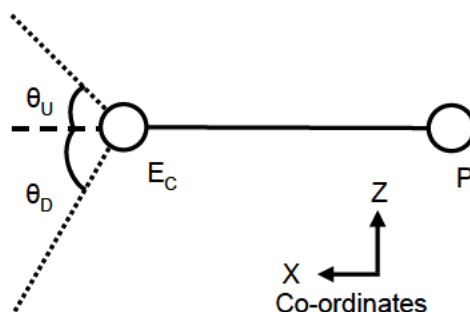

Figure 19_5: Side view of vertical eye point rotations

6.8 Camera Points

The field of view provided by each camera of a camera-monitor system (CMS) shall be defined by monocular vision originating from a specified camera point location from which sightlines will originate. Multiple camera point locations (C_1 , C_2 ... C_n) and fields of view may be defined for assessment.

6.9 Camera Point Locations (C)

Camera point locations (C), relative to the origin of the global coordinate system, shall be provided by the OEM for all CMS included in the BVS assessment. Each camera point location (C_1 , C_2 ... C_n) shall be located at the origin of the field of view for the relevant camera.

6.10 Camera Point Fields of View (α , λ)

The angle of the centre of the field of view shall be provided for each camera point (C_n) by the OEM, as shown in Figure 19_66 and Figure .

The horizontal angle shall be formed between the centre of the field of view and XZ plane (α_n), with a positive value used when angled outboard relative to the XZ plane.

The maximum range of the horizontal field of view, both inboard and outboard (α_{n_I} , α_{n_O}), for each camera point (C_n) shall be provided by the OEM, as shown in Figure 19_6.

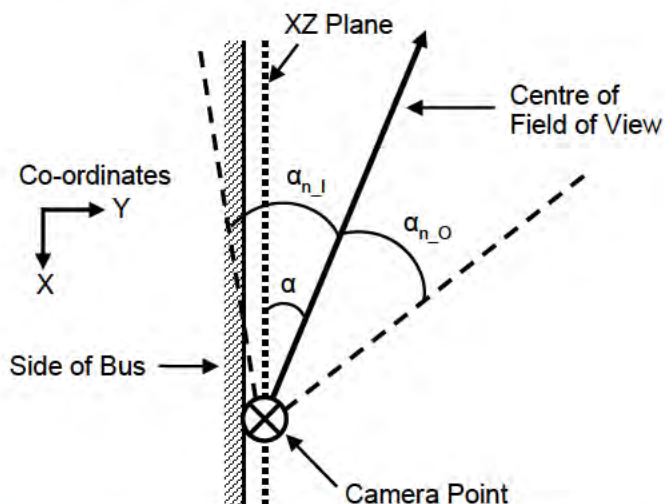

Figure 19_6: Plan view of horizontal field of view range for camera point

The vertical angle shall be formed between the centre of the field of view and XY plane (λ_n), with a positive value used when angled downward relative to the XY plane.

The maximum range of the vertical field of view, both upward and downward ($\lambda_{n,U}$, $\lambda_{n,D}$), for each camera point (C_n) shall be provided by the OEM, as shown in Figure 19_7.

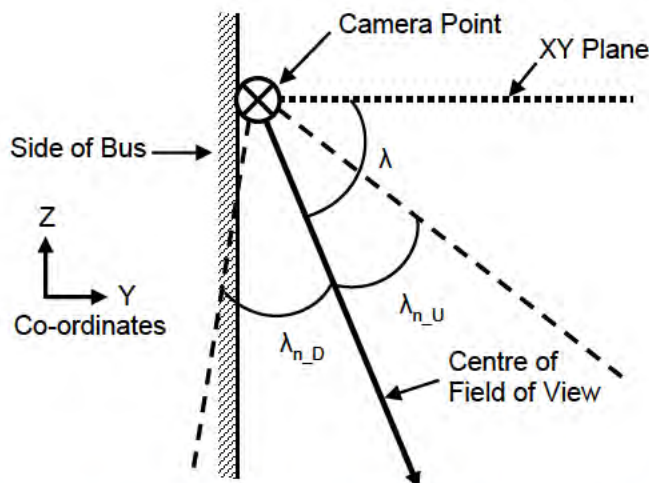

Figure 19_7: Frontal view of vertical field of view range for camera point

6.11 Assessment Zones

The following three assessment zones shall be defined:

- Forward Close Proximity Zone
- Rearward Close Proximity Zone
- Wide-Angle Zone

Where these assessment zones are defined in relation to the limits of the vehicle length and width, these limits shall include all relevant vehicle glazing and bodywork, but exclude all features listed in Appendix A.

6.12 Assessment Zone Height

Each assessment zone shall be formed by a volume, including the following defined areas, at heights from $Z = 1.177$ m through to $Z = 1.602$ m from the ground plane.

6.13 Forward Close Proximity Zone

The dimensions of the forward close proximity assessment zone are shown in Figure 19_8 to 19_10 and described below:

- The fore outer boundary of the assessment zone is defined by a YZ plane located 2 m in front (+X axis) of the foremost aspect of the vehicle structure.
- The nearside (left side) outer boundary of the assessment zone is defined by a XZ plane located 4.5 m outboard (+Y axis) from the most lateral aspect of the nearside of the vehicle structure.
- The offside (driver side) outer boundary of the assessment zone is defined by a XZ plane located 2 m outboard (-Y axis) from the most lateral aspect of the offside of the vehicle structure.
- The rear outer boundary of the assessment zone is defined by a YZ plane located 1.75 m to the rear (-X axis) of the reference eye point (E_{ref}).
- The inner boundary is located 0.3m from the outermost aspect of the vehicle structure, when measured normal to the relevant vehicle structure (Figure . This may include curves, dependant on the geometry of the outmost vehicle structure.
- Assessment Zone height as per Section 4.12, shown in Figure 19_10

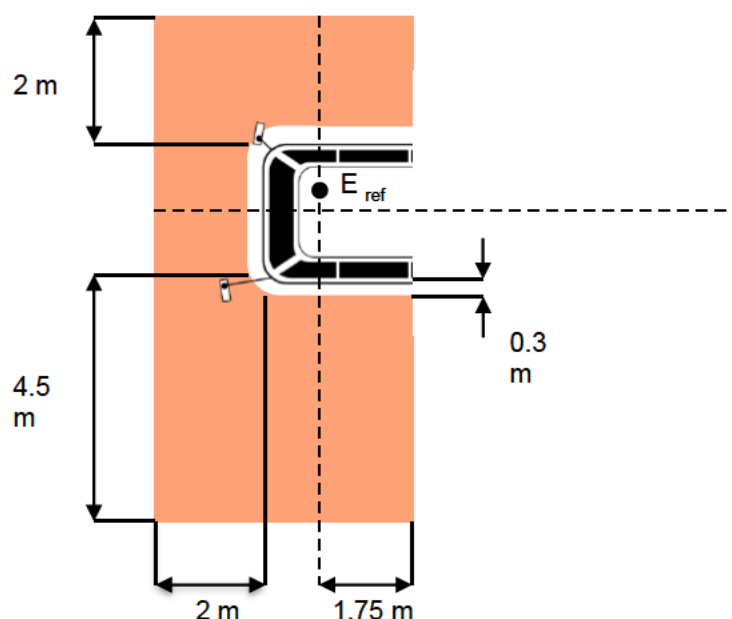

Figure 19_8: Plan view of forward close proximity assessment zone

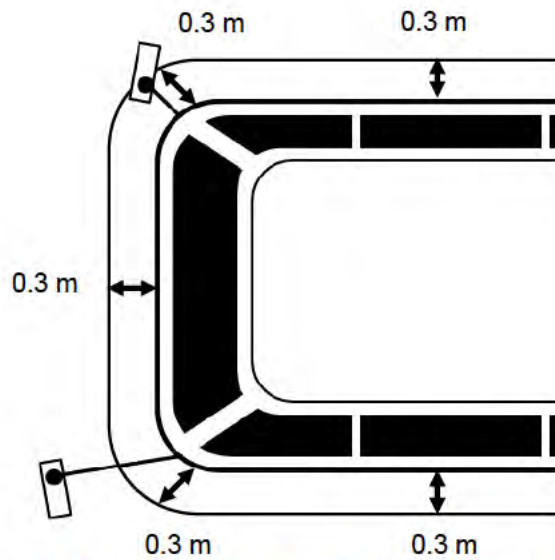

Figure 19_9: Illustration of profile for defining inner boundary of assessment zones

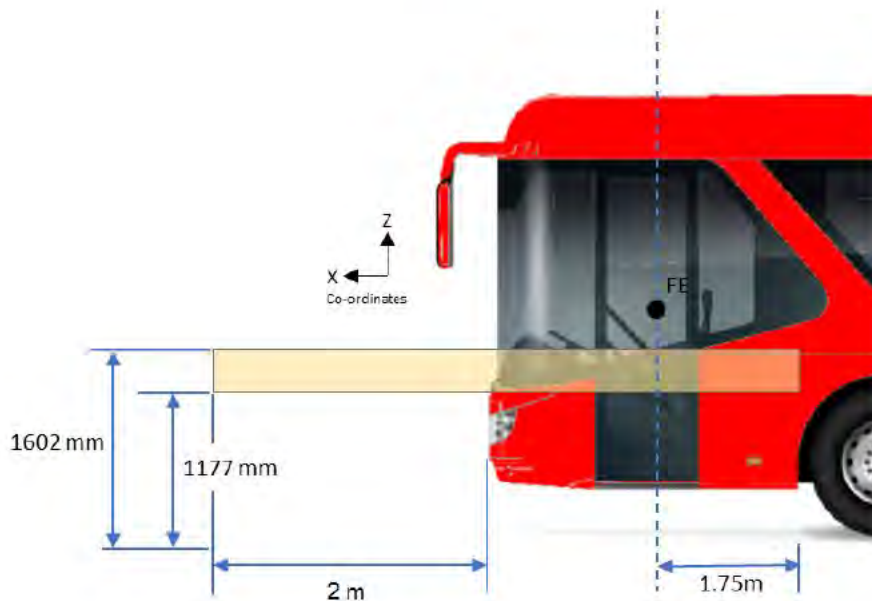

Figure 19_10: Side view of forward close proximity assessment zone

6.14 Rearward Close Proximity Zone

The dimensions of the rearward close proximity assessment zone are shown in Figure 19_11 and 19_12 and described below:

- a) The fore outer boundary of the assessment zone is defined by a YZ plane and located 1.75 m to the rear (-X axis) of the reference eye point (E_{ref}).



- b) The nearside (left side) outer boundary of the assessment zone is defined by XZ plane and located 4.5 m outboard (+Y axis) from the most lateral aspect of the nearside of the vehicle structure.
- c) The offside (driver side) outer boundary of the assessment zone is defined by a XZ plane and located 2 m outboard (-Y axis) from the most lateral aspect of the offside of the vehicle structure.
- d) The rear outer boundary of the assessment zone is defined by a YZ plane and located 5 m to the rear (-X axis) of the rearmost aspect of the vehicle structure.
- e) The inner boundary is located 0.3 m from the outermost aspect of the vehicle structure, when measured normal to the relevant vehicle structure (Figure 19_11). This may include curves, dependant on the geometry of the outmost vehicle structure.
- f) Assessment Zone height as per Section 4.12, shown in Figure 19_12

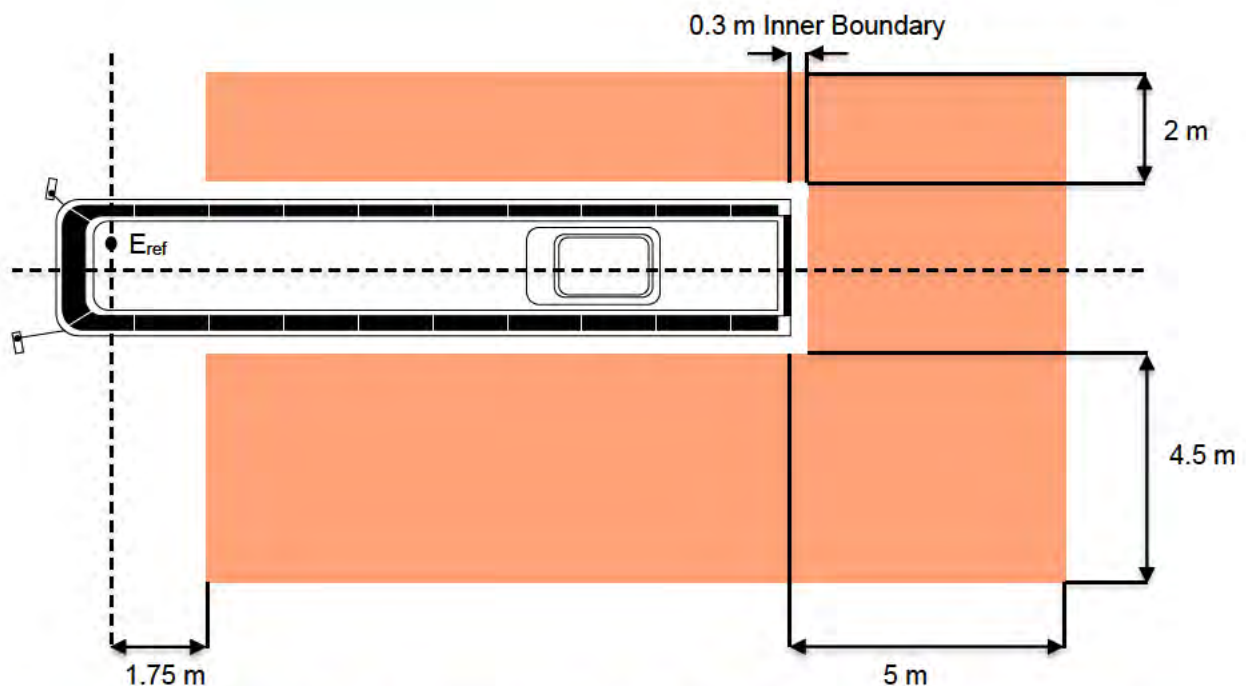

Figure 19_11: Plan view of rearward close proximity assessment zone



Figure 19_12: Side view of rearward close proximity assessment zone

6.15 Wide-Angle Zone

The dimensions of the wide-angle assessment zones, which are principally based on the field of vision zones specified for Class IV mirrors in UN ECE Regulation 46, are shown in Figure 19_13 and 19_14 and described below:

- a) Nearside (left side) wide-angle assessment zone:
 - i. The fore boundary of the assessment zone is defined by a YZ plane, located 1.5 m rear (-X axis) of the reference eye point (E_{ref}).
 - ii. The rear boundary of the assessment zone is defined by a YZ plane located 25 m to the rear (-X axis) of the reference eye point (E_{ref}).
 - iii. The outer boundary of the assessment zone is defined by a XZ plane, located 15 m outboard (+Y axis) from the most lateral aspect of the nearside of the vehicle structure and a Z plane between 1.5 m rear (-X axis) of the reference eye point (E_{ref}) and 4.5 m outboard (+Y axis) from the most lateral aspect of the nearside of the vehicle structure and 10 m to the rear (-X axis) of the reference eye point (E_{ref}) and 15 m outboard (+Y axis) from the most lateral aspect of the nearside of the vehicle structure .
 - iv. The inner boundary of the assessment zone is defined by a XZ plane, located 4.5 m outboard (+Y axis) from the most lateral aspect of the nearside of the vehicle structure
 - v. Assessment Zone height as per Section 4.12, shown in Figure 19_14
- a) Offside (driver side) wide-angle assessment zones:
 - i. The fore boundary of the assessment zone is defined by a YZ plane, located 1.5 m to the rear (-X axis) of the reference eye point (E_{ref})
 - ii. The rear boundary of the assessment zone is defined by a YZ plane and located 25 m to the rear (-X axis) of the reference eye point (E_{ref})
 - iii. The outer boundary of the assessment zone is defined by a XZ plane, located 15 m outboard (-Y axis) from the most lateral aspect of the nearside of the vehicle structure and a Z plane between 1.5 m rear (-X axis) of the reference eye point (E_{ref}) and 4.5 m outboard (+Y axis) from the most lateral aspect of the nearside of the vehicle structure and 10 m to the rear (-X axis) of the reference eye point (E_{ref}) and 15 m outboard (+Y axis) from the most lateral aspect of the nearside of the vehicle structure



- iv. The inner boundary of the assessment zone is defined by a XZ plane and located 2 m outboard (-Y axis) from the most lateral aspect of the nearside of the vehicle structure
- v. Assessment Zone height as per Section 4.12, shown in Figure 19_14

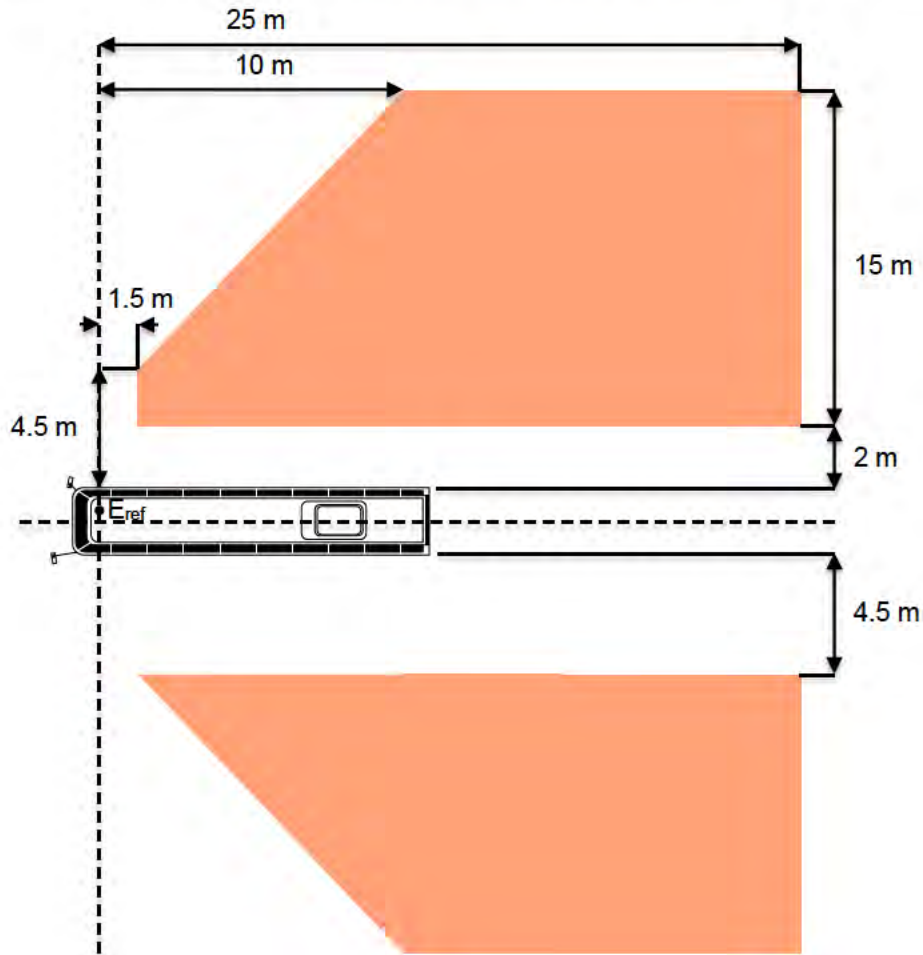

Figure 19_13: Plan view of wide-angle assessment zone



Figure 19_14: Side view of wide-angle assessment zone



6.16 Assessment Zone Elements

Each assessment zone volume shall be split into individual, 3 dimensional elements, approximately equal in both size and shape, with no single dimension exceeding 0.1m.

7 Vehicle preparation

7.1 CAD Model

The assessment requires a CAD model of the VUT that is of sufficient detail to allow accurate measurement of the direct and indirect fields of view available to the driver (Figure). This can either be supplied by the OEM or generated from laser scanning a physical vehicle where independent evaluation is considered necessary. The resulting CAD data must include any interior and exterior component geometry which may obstruct or reflect the sightline, including but not limited to:

- a) Exterior panels that bound any transparent area
- b) Exterior panels that define the extents of the vehicle to the front (e.g. bumper) and sides (e.g. wheel arches)
- c) Exterior elements that may obstruct driver vision including; mirrors and mirror arms, wipers and any other OEM fit feature or equipment
- d) Exterior mirrored surfaces that may reflect driver vision
- e) Interior surfaces that may obstruct driver vision including; the driver assault screen frame, dashboard, window seals/rubbers, trim panels on doors, A-pillars, B-pillars, grab handles, etc.
- f) Interior equipment that may obstruct driver vision including; ticket machines, rain sensors, monitors/screens or other controls or displays, etc.
- g) Key elements of the driver packaging including; seats, steering wheel, etc, and the AHP.



Figure 19_15: Example CAD data required for bus vision standard assessment

7.2 Glazing Frit

Where glazing incorporates a 'frit' (also known as 'black-off' or 'fade-off'), this area should be considered opaque. Thus, the daylight opening (DLO) boundary is defined by the inner boundary of any patterned area, as shown in Figure below.

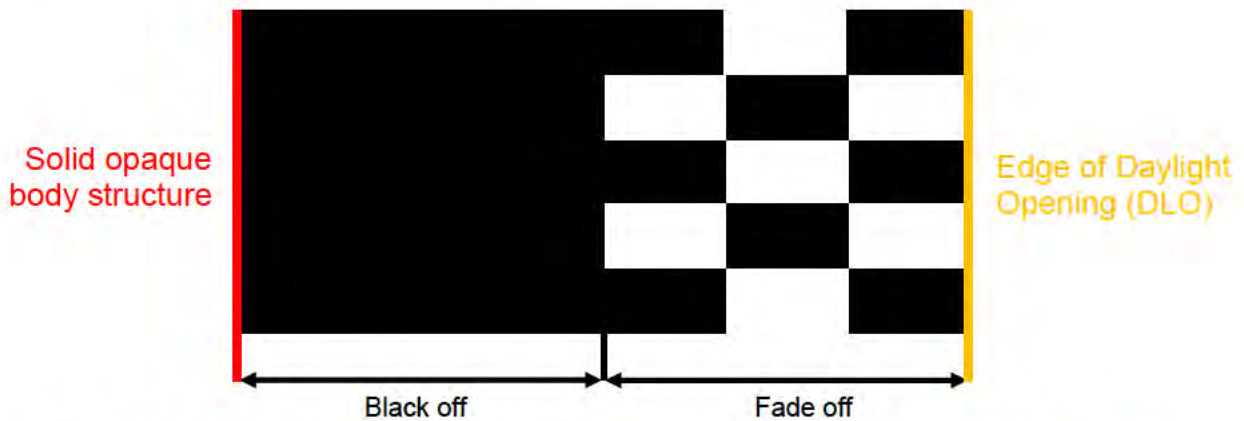

Figure 19_16: Definition of daylight opening (DLO) at window edges with black-off or fade-off areas

7.3 Tinting

Where any area of a windscreen or other glazed surface has a light transmittance of less than 70% (when measured normal to the surface), this area should be considered opaque. Thus, the DLO boundary is further defined by the boundaries of any tinted areas.

7.4 Glazing Angle

Where the angle of incidence (θ_i) between the surface of any section of glazing and the sightline from the eye is angled at greater than 74° , when looking at the surface from any angle, this area shall be considered opaque (Figure 19_17). The DLO boundary is therefore further defined by the boundaries of any glazed surfaces defined as opaque.

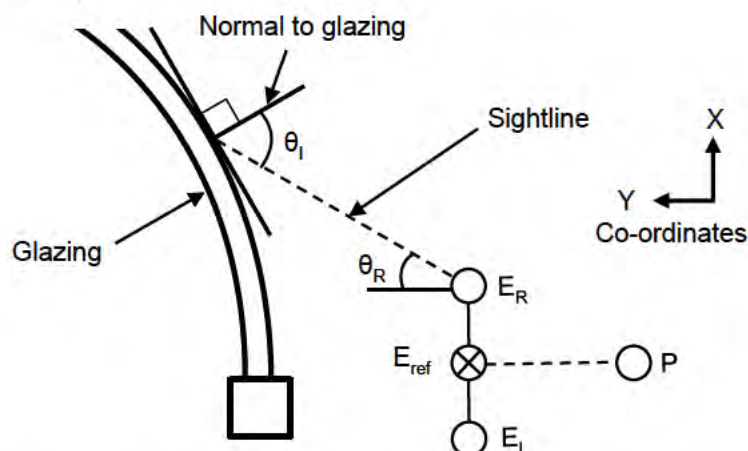

Figure 19_17: Illustration of angle of incidence between the sightline and glazing



7.5 Mirror Positioning

Accurate CAD models of mirror surfaces, mirror housings and mirror arms shall be included. Curved surfaces for non-planar mirrors shall be included. Mirror surfaces and mirror arm model information shall be recorded.

Mirror arms and housing shall be positioned in their in-use position, i.e. not stowed away.

If mirror housings provide a range of adjustment in their in-use position, they shall be adjusted to a representative position for the assessment. The angles that the mirror housing makes relative to the X, Y, and Z-axes of the vehicle shall be recorded, alongside the position of the attachment to the mirror arm.

Mirror surfaces shall then be adjusted within the mirror housing to meet UN ECE Regulation 46 requirements.

All mirrors, mirror housings and mirror arms shall be adjusted within OEM defined ranges of motion. All mirrored surfaces shall comply with the requirements relating to the radii of curvature in UN ECE Regulation 46. Any mirror not complying with these requirements shall be designated as part of the vehicle structure.

7.6 Camera-Monitor Systems (CMS)

Accurate CAD models of the exterior geometries for the camera, camera housing and monitor shall be included. Monitors shall be positioned in their OEM recommended positions, i.e. not stowed away. All camera-monitor systems (CMS) shall comply with UN ECE Regulation 46 requirements. Any CMS not complying with these requirements shall be designated as part of the vehicle structure.

7.7 Accelerator Heel Point (AHP) Height

Where different running gear (tyres, wheels, suspensions) are available on the same model, then by default, the CAD data shall reflect the worst-case configuration. This shall be the configuration that results in the AHP being at the greatest possible distance from the ground plane. The results of this assessment may then be applied to all variants with identical bodywork and mirror arrangements where the AHP is nearer to the ground. Alternatively, the OEM may at their discretion assess more than one variant. CAD data shall represent a bus in the following running order:

- a) The suspension enabling the vehicle ground clearance to be adjusted, if applicable, is set to the highest setting for normal driving
- b) The specified tyres should be at their maximum ETRTO diameter
- c) The tyre pressures are set according to OEM's recommendations
- d) The fuel tank is filled to no greater than 10% of the capacity specified by the OEM
- e) Other fluid levels, such as lubricants, coolants, etc., are set according to OEM's recommendations
- f) The driver seat is occupied with a driver of 68 kg mass
- g) No additional payload or passenger ballast is added



7.8 Steering Wheel Position

The steering wheel shall be positioned in the geometric centre of the steering wheel adjustment envelope, as defined by the OEM.

7.9 Driver Seat Position

The driver seat shall be located at the rearmost and lowest point of the driver seat adjustment envelope, as defined by the OEM.

7.10 Accelerator Heel Point (AHP)

The CAD data shall contain a definition of the Accelerator Heel Point (AHP). The AHP is a key reference point for the definition of the eye points used for the assessment and shall be defined as per the process documented in SAE J1516, SAE J1517 and SAE J1100.

7.11 Other Vehicle Components

Adjustable equipment designed for intermittent use during rare circumstances while driving, such as windscreen wipers or windscreen sun visors, or for non-driving use shall be set in the not-in-use or stowed away position.

Adjustable equipment designed for regular use or that may reasonably be expected to be left permanently in the in-use position by most drivers, such as adjustable armrests, shall be in the in-use position and adjusted to represent the worst-case obstruction to direct vision, as determined by the test service.

All internal components entirely obstructed by the driver cab, such as passenger seats, poles, staircase, may be removed to speed up the simulation process. Such internal components have no effect on the vision zones.

8 Test procedure

Technically, it is possible to undertake this assessment using CAD software alone. However, it is considered that it would be very complex and time consuming. It is, therefore, recommended that the CAD models of both the vehicle and assessment zone are assessed using an automated computer programme.

An example of the sightlines to be assessed can be found in the breakdown of the neck pivot point and eye point angles provided in Appendix B.

8.1 Sightline Projection

Sightline projections shall be made and analysed according to the following procedure for a combination of different neck pivot point angles (β), measured at 10° increments, and eye point angles (θ), within the ranges defined in Section 4.

Sightline projections shall also be made and analysed for camera field of vision angles (α , λ), within the ranges specified by the OEM..

Each sightline shall be projected from a point of origin located at the cyclopean eye point or camera point location to be assessed.



The angle between each sightline, whether projected from the eye point or a camera, shall be such that each of the assessment zone elements may be intersected where no obstruction exists. For example, where elements of 0.1m have been used at a distance of 3m from the Eye point, angular increments of 1.5° or less should be used.

Each sightline shall be increased in length in increments of 0.1 m, to project along the eye point or camera point angle, until the sightline reaches a length of 40 m or intersects with the following:

- a) An opaque vehicle structure not defined as a mirrored surface. In this case, the projection of the sightline shall be terminated at the obstruction point.
- b) An opaque vehicle structure that is defined as a mirrored surface. In this case, the sightline shall be geometrically reflected by mirroring the angle of incidence relative to the normal of the mirror surface at the obstruction point.
- c) The end of the assessment zone.

8.2 Determining the Direct Vision Volume (V_D)

The determination of the Direct Vision Volume must be conducted before other vision volumes to ensure the Bus Vision Score weighting calculations are correctly applied.

All assessment zone elements intersected by a sightline originating from the cyclopean eye point (i.e. not at a camera point), but that has not been reflected from a mirrored surface, shall be designated as visible through the direct field of vision of the driver.

The volume of these individual elements shall be summed to form the direct vision volume (V_D).

The assessment procedure must ensure that any assessment zone element which is counted as part of the Direct Vision Volume is prevented from being counted again as part of the Indirect Vision Volume. This is to prevent the double counting of any individual element which may produce a biased result.

All volumes shall be calculated in cubic millimetres (mm^3) and to the nearest decimal place.

8.3 Determining the Indirect Vision Volume (V_I)

8.3.1 Indirect Vision Volume (V_I)

The indirect vision volume (V_I) associated with each assessment zone shall be calculated through the summation of the indirect vision volume for mirrors ($V_{I,M}$) and the indirect vision volume for CMS ($V_{I,C}$).

Thus, for each assessment volume:

$$V_I = V_{I,M} + V_{I,C}$$

All volumes shall be calculated in cubic millimetres (mm^3) and to the nearest decimal place.



8.3.2 Mirrors ($V_{I,M}$)

All assessment zone elements intersected by a sightline originating from the cyclopean eye point (i.e. not at a camera point) after having been reflected from a mirrored surface shall be designated as visible through the indirect field of vision of the driver using a mirror.

Any elements that have been found to be visible via the direct field of vision must not be included in this assessment to avoid “double counting” any elements..

The volume of these individual elements shall be summed to form the indirect vision volume for mirrors ($V_{I,M}$).

8.3.3 Camera-monitor Systems (CMS) ($V_{I,C}$)

All assessment zone elements intersected by a sightline originating from a camera point, but that have not been found to be visible via either the direct field of vision or via reflection by a mirrored surface, shall be designated as visible through the indirect field of vision of the driver using a CMS.

The volume of the individual elements shall be summed to form the indirect vision volume for CMS ($V_{I,C}$).

8.4 Determining the Total Driver Vision Volume (V_T)

The total driver vision volume (V_T) associated with each assessment zone shall be calculated through the summation of the Direct vision volume (V_D) and the Indirect vision volume (V_I).

Thus, for each assessment volume:

$$V_T = V_D + V_I$$

All volumes shall be calculated in cubic millimetres (mm^3) and to the nearest decimal place.

8.5 Determining the Blind Spot Volume (V_B)

The blind spot volume (V_B) associated with each assessment zone shall be calculated through the subtraction of the total driver vision volume (V_T) from the assessment zone volume (V_A).

Thus, for each assessment volume:

$$V_B = V_A - V_T$$

All volumes shall be calculated in cubic millimetres (mm^3) and to the nearest decimal place.



9 Assessment of results

9.1 Direct Vision Performance Score (DVS)

The direct vision performance score calculates the proportion of each assessment zone visible to the driver through the direct field of view. This is calculated by dividing the relevant direct vision volume (V_D) by the assessment zone volume (V_A).

Thus, for each assessment volume:

$$DVS = \frac{V_D}{V_A} \%$$

The direct vision performance score shall be calculated as a percentage to [a single] decimal place.

9.2 Indirect Vision Performance Score (IVS)

The indirect vision performance score calculates the proportion of each assessment zone visible to the driver through the indirect field of view. This is calculated by dividing the relevant indirect vision volume (V_I) by the assessment zone volume (V_A).

Thus, for each assessment volume:

$$IVS = \frac{V_I}{V_A} \%$$

The indirect vision performance score shall be calculated as a percentage to [a single] decimal place.

9.3 Total Driver Vision Performance Score (TVS)

The total driver vision performance score calculates the proportion of each assessment zone visible to the driver through the direct and indirect fields of view. This is calculated by dividing the relevant total driver vision volume (V_T) by the assessment zone volume (V_A).

Thus, for each assessment volume:

$$TVS = \frac{V_T}{V_A} \%$$

The total driver vision performance score shall be calculated as a percentage to a single decimal place.

9.4 Bus Vision Standard Performance Rating Score (BVS)

The bus vision standard performance rating score calculates a normalised, weighted, score to provide an overall rating score to describe the relative safety performance of different vehicles.

[London collision data has been used to weight the importance of each assessment zone with respect to the potential casualty prevention potential of each zone around the vehicle.] This has been combined with research further weighting the differences



in importance between direct and indirect vision with respect to their relative casualty prevention potentials. These weighting factors are shown in Table _1.

Table 19_1: Weighting factors for each assessment zone

Assessment Zone	Direct Vision Weighting Factor (W_D)	Indirect Vision Weighting Factor (W_I)	Casualty Weighting Factor (W_C)
Forward Close Proximity Zone	100%	50%	[69]%
Rearward Close Proximity Zone	-	100%	[28]%
Wide Angle Zones	-	100%	[3]%

Note: Rearward close proximity and wide angle zones should be visible through indirect vision only

The weighted bus vision standard performance rating score for each assessment zone is calculated by the summation of the weighted direct and indirect vision performance scores, calculated by multiplying the DVS and IVS with the relevant casualty weighting factor.

$$\text{Zone BVS} = W_C(DVS \times W_D) + (IVS \times W_I)$$

The overall bus vision standard performance rating score (BVS) of the VUT shall be calculated by summing the weighted scores of each assessment zone and shall be calculated as a percentage to a single decimal place.

Table 9_2 shows hypothetical results as a worked example.

Table 19_2: Example scoring and weighting process to obtain the overall bus vision standard performance rating score (BVS) for the VUT

Assessment Zone	DVS	W_D	IVS	W_I	W_C	BVS
Forward Close Proximity Zone	89.7%	100%	5.2%	50%	[69]%	63.7%
Rearward Close Proximity Zone	-	-	30.3%	100%	[28]%	8.5%
Wide Angle Zones	-	-	12.8%	100%	[3]%	0.4%
Overall BVS						72.6%



10 Test report

The Test Service shall provide a comprehensive Test Report that will be made available to TfL. The test report shall consist of three distinct sections:

- a) Performance data
- b) Confirmation of protocol compliance
- c) Reference information

10.1 Performance Data

Table 19_3: Performance data template for test report shows the performance data to be produced for each vehicle assessed.

Table 19_3: Performance data template for test report

Performance Measure	Forward Close Proximity Zone	Rearward Close Proximity Zone	Wide Angle Zones
Assessment Zone Volume (V_A) /mm³			
Direct Vision Volume (V_D) /mm³		-	-
Indirect Vision Volume for Mirrors (V_{I_M}) /mm³			
Indirect Vision Volume for Cameras (V_{I_C}) /mm³			
Indirect Vision Volume (V_I) /mm³			
Total Driver Vision Volume (V_T) /mm³			
Blind Spot Volume (V_B) /mm³			
Direct Vision Performance Score (DVS) /%			
Indirect Vision Performance Score (IVS) /%			
Total Driver Vision Performance Score (TVS) /%			
Bus Vision Standard Performance Score (BVS) /%			
Overall Bus Vision Standard Performance Score (BVS) /%			



In addition to the necessary performance data, the Test Service shall provide images with the Test Report illustrating the visible volumes and blind spots associated with each assessment volume. As a minimum requirement, these images shall include a plan view of the blind spot volumes associated with each assessment zone but may also be combined with images including isometric views, side views, etc. to support understanding of the principle causes of the blind spots. Such images shall be colour coded to distinguish between the visible and blind spot volumes and may also be separated by whether areas are visible by direct or indirect vision (mirrors/cameras). A legend to the colour coding shall be provided within the Test Report. Hypothetical examples are shown in Figure 19_18.

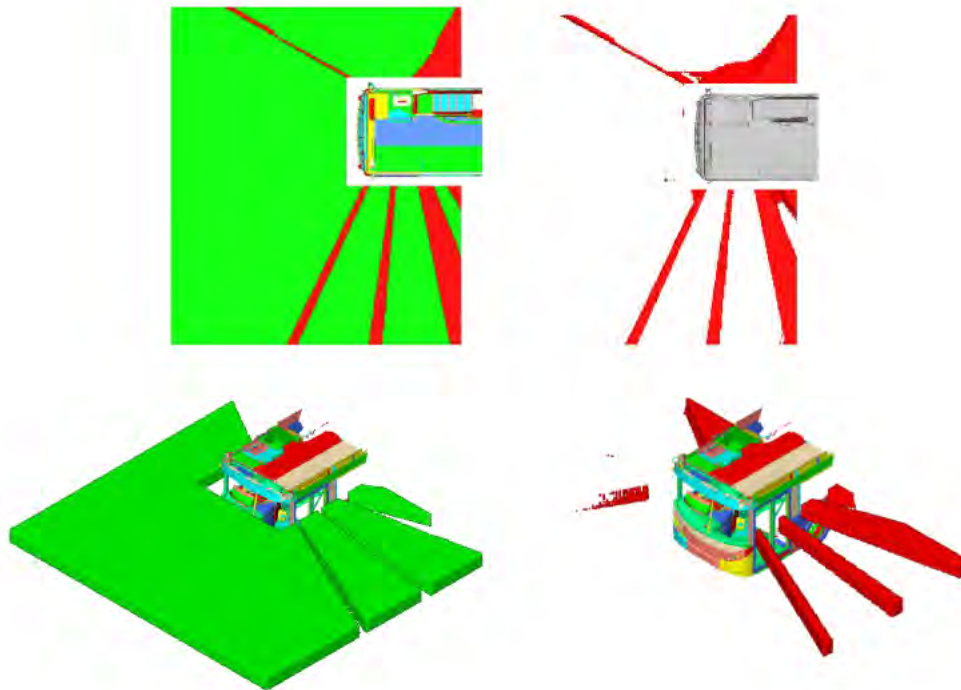

Figure 19_18: Example images showing Direct Vision Volume (green) and Blind Spot Volume (red) for the forward close proximity assessment zone

10.2 Protocol Compliance

To confirm protocol compliance, the Test Service shall provide information including:

- Details of the software packages used (e.g. CAD software)
- Origin of the CAD model (i.e. from OEM or result of laser scan).
- Information that may be used to verify the level of detail of the CAD model.
- Minimum and maximum element sizes used for the assessment zones.

10.3 Reference Information

As a minimum, the Test Service shall provide reference information including:

- Vehicle make
- Vehicle model



- c) Vehicle model variant
- d) Vehicle running order information
- e) Vehicle steering wheel and driver seat positions
- f) AHP location
- g) Mirror and mirror arm model/s fitted
- h) CMS model/s fitted, if applicable
- i) Mirror positioning, including information on locations and adjustment angles
- j) CMS information, including locations and fields of view
- k) Details on any glazed areas defined as opaque (due to frit/tinting/angle)
- l) Details of the Test Service
- m) Test date(s)



Appendix A - Components excluded in defining the assessment zones

Vehicle length

Vehicle length relates to a dimension is measured according to ISO standard 612-1978, term No. 6.1. In addition to the provisions of this standard, when measuring vehicle length, the following components shall not be taken into account:

- Wiper and washer devices
- Front or rear marker-plates
- Customs sealing devices and their protection
- Devices for securing the load restraint(s)/cover(s) and their protection
- Lighting and light signalling devices
- Mirrors or other devices for indirect vision
- Reversing aids
- Air-intake pipes
- Length stops for demountable bodies
- Access steps and hand-holds
- Ram rubbers and similar equipment
- Lifting platforms, access ramps and similar equipment in running order, not exceeding 300 mm
- Coupling and recovery towing devices for power driven vehicles
- Trolleybus current collection devices in their elevated and retracted positions
- External sun visors
- De-mountable spoilers
- Exhaust pipes

Vehicle width

Vehicle width relates to a dimension is measured according to ISO standard 612-1978, term No. 6.2. In addition to the provisions of this standard, when measuring the vehicle width, the following components shall not be taken into account:

- Customs sealing devices and their protection
- Devices for securing the tarpaulin and their protection
- Tyre failure tell-tale devices
- Protruding flexible parts of a spray-suppression system
- Lighting and light signalling devices
- For buses, access ramps, lifting platforms and similar equipment in their stowed position
- Rear-view mirrors or other devices for indirect vision,
- Tyre-pressure indicators
- Retractable steps
- The deflected part of the tyre walls immediately above the point of contact with the ground
- External lateral guidance devices of guided buses
- Running boards
- De-mountable mudguard broadening



Appendix B - Example breakdown of head and eye angles

Head Angles (degrees)

		-90	-80	-70	-60	-50	-40	-30	-20	-10	0	10	20	30	40	50	60	70	80	90	
Vertical	0	X	X	X	X	X	X	X	X	X	X	X	X	X	X	X	X	X	X	X	X

Eye Angle (degrees)

		Horizontal																				
		-30	-27	-24	-21	-18	-15	-12	-9	-6	-3	0	3	6	9	12	15	18	21	24	27	30
Vertical	-60	X	X	X	X	X	X	X	X	X	X	X	X	X	X	X	X	X	X	X	X	X
	-57	X	X	X	X	X	X	X	X	X	X	X	X	X	X	X	X	X	X	X	X	X
	-54	X	X	X	X	X	X	X	X	X	X	X	X	X	X	X	X	X	X	X	X	X
	-51	X	X	X	X	X	X	X	X	X	X	X	X	X	X	X	X	X	X	X	X	X
	-48	X	X	X	X	X	X	X	X	X	X	X	X	X	X	X	X	X	X	X	X	X
	-45	X	X	X	X	X	X	X	X	X	X	X	X	X	X	X	X	X	X	X	X	X
	-42	X	X	X	X	X	X	X	X	X	X	X	X	X	X	X	X	X	X	X	X	X
	-39	X	X	X	X	X	X	X	X	X	X	X	X	X	X	X	X	X	X	X	X	X
	-36	X	X	X	X	X	X	X	X	X	X	X	X	X	X	X	X	X	X	X	X	X
	-33	X	X	X	X	X	X	X	X	X	X	X	X	X	X	X	X	X	X	X	X	X
	-30	X	X	X	X	X	X	X	X	X	X	X	X	X	X	X	X	X	X	X	X	X
	-27	X	X	X	X	X	X	X	X	X	X	X	X	X	X	X	X	X	X	X	X	X
	-24	X	X	X	X	X	X	X	X	X	X	X	X	X	X	X	X	X	X	X	X	X
	-21	X	X	X	X	X	X	X	X	X	X	X	X	X	X	X	X	X	X	X	X	X
	-18	X	X	X	X	X	X	X	X	X	X	X	X	X	X	X	X	X	X	X	X	X
	-15	X	X	X	X	X	X	X	X	X	X	X	X	X	X	X	X	X	X	X	X	X
	-12	X	X	X	X	X	X	X	X	X	X	X	X	X	X	X	X	X	X	X	X	X
	-9	X	X	X	X	X	X	X	X	X	X	X	X	X	X	X	X	X	X	X	X	X
	-6	X	X	X	X	X	X	X	X	X	X	X	X	X	X	X	X	X	X	X	X	X
	-3	X	X	X	X	X	X	X	X	X	X	X	X	X	X	X	X	X	X	X	X	X
	0	X	X	X	X	X	X	X	X	X	X	X	X	X	X	X	X	X	X	X	X	X
	3	X	X	X	X	X	X	X	X	X	X	X	X	X	X	X	X	X	X	X	X	X
	6	X	X	X	X	X	X	X	X	X	X	X	X	X	X	X	X	X	X	X	X	X
	9	X	X	X	X	X	X	X	X	X	X	X	X	X	X	X	X	X	X	X	X	X
12	X	X	X	X	X	X	X	X	X	X	X	X	X	X	X	X	X	X	X	X	X	
15	X	X	X	X	X	X	X	X	X	X	X	X	X	X	X	X	X	X	X	X	X	
18	X	X	X	X	X	X	X	X	X	X	X	X	X	X	X	X	X	X	X	X	X	
21	X	X	X	X	X	X	X	X	X	X	X	X	X	X	X	X	X	X	X	X	X	
24	X	X	X	X	X	X	X	X	X	X	X	X	X	X	X	X	X	X	X	X	X	
27	X	X	X	X	X	X	X	X	X	X	X	X	X	X	X	X	X	X	X	X	X	
30	X	X	X	X	X	X	X	X	X	X	X	X	X	X	X	X	X	X	X	X	X	
33	X	X	X	X	X	X	X	X	X	X	X	X	X	X	X	X	X	X	X	X	X	
36	X	X	X	X	X	X	X	X	X	X	X	X	X	X	X	X	X	X	X	X	X	
39	X	X	X	X	X	X	X	X	X	X	X	X	X	X	X	X	X	X	X	X	X	
42	X	X	X	X	X	X	X	X	X	X	X	X	X	X	X	X	X	X	X	X	X	
45	X	X	X	X	X	X	X	X	X	X	X	X	X	X	X	X	X	X	X	X	X	